

# Use of the Eddystone '898' Drive Unit in an HBR 13C Homebrew Receiver - by Gerry O'Hara, G8GUH/VE7GUH

## Introduction

Scanning EBay auctions (as you do) for Eddystone receivers and other items, I have noted that some of the most popular 'accessories' are the drive units manufactured by Eddystone for incorporation into 'homebrew' radio amateur equipment as well as commercial instruments. The '3174p' unit (photo, left) provided a 'half moon' drive scale configuration, whereas the '898' drive unit (photo, below) was based on the superlative 'slide rule' dial that had formed the basis of Eddystone's reputation of high quality, solidly-built and silky-smooth to the touch tuning mechanisms found in their receivers manufactured from 1950 through the 1970's. Both of these dial drives appear regularly on EBay, though the latter seems to be more prevalent (an average of

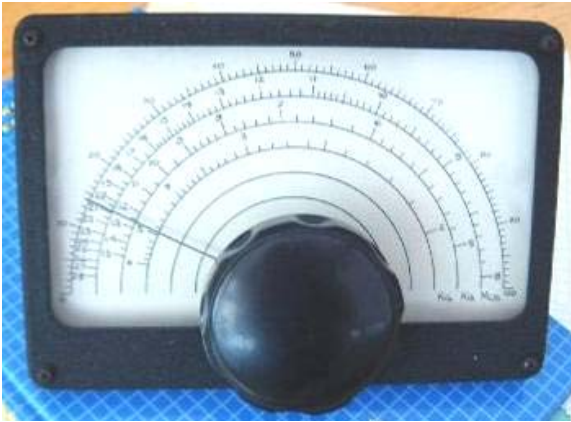

around one a month in 2007) and usually commands a significant price, especially for units that have not had scale markings added and are supplied with their original box, chassis-marking template and are in 'mint' condition. In the last year have noticed such units sell for between around £20 (\$40) and £60 (\$120). Interestingly, the '898' drives frequently appear for sale on this side of the 'pond' (usually in the US), and from time to time, also in Australia and Europe. This confirms that the word about the Eddystone dial reputation had spread far and wide, at least amongst radio amateurs worldwide.



Above: a very nice example of an '898', complete with original paperwork and box

So, no, I have not bought one of these units (as I have nothing to install it into at the moment or planned in this regard) and I cannot really justify forking out \$100 or so just

to have one to play with/sit on a shelf/write an article about... Instead, I thought it would be of interest to describe the context of their use, and provide some detail of an excellent example of a homebrew receiver that was effectively 'built-around' an '898' dial mechanism that I came across recently.

### The '898' Mechanism

Eddystone Data Sheet No. 124, dated September, 1959, identifies the 'Cat. No. 898' as a 'Geared Slow-Motion Drive Assembly', describing it thus:

*"A high grade assembly designed for instrument applications. The movement is gear-driven and flywheel loaded, giving a smooth, positive drive, with a reduction ratio of 110:1.*

*The pointer has a horizontal travel of 7 inches. A circular vernier scale, marked over 100 divisions, rotates five times for one traverse of the pointer, and, read with the "100" scale on the dial, provides a total of 500 divisions. The dial has five lines to take calibration markings.*

*A diecast escutcheon, finished in glossy black, is supplied and the assembly is complete with Perspex window, knob, fixing screws, and mounting template. It is suitable for mounting on metal or wooden panels up to 7mm. thick. Overall external dimensions are  $9\frac{3}{16}$ " (23.34 cms.) by  $5\frac{3}{4}$ " (14.6cms.). Weight is approximately 1 lb. 14 oz. (0.85 kilogrammes)."*

The mechanism is extremely simple (photo, below): the drive-shaft passes through a bearing at the base of the 'gearbox' housing. A cast alloy flywheel is mounted onto the shaft together with an Eddystone Cat. No. 591 style knob and the spring-loaded friction drive pinch-wheel. This engages with a steel friction wheel, mounted on an idler shaft above, along with the vernier logging scale and a brass pinion. The latter engages with a spring-loaded split brass gear wheel mounted on another idler shaft passing through the upper end of the gearbox. A stop-boss is located on the rear gear wheel to limit travel. This gear wheel engages with the two brass spool pulleys. The dial cord is spooled onto the brass pulleys and



passes around two clear plastic idler pulleys located either side of the steel plate behind the scale. The pointer is fixed to the cord with a clip and the cord is tensioned by a spring-loaded mount on one of the plastic idler pulleys (left in photo above).

### **A Donation to SPARC**

The Society for the Preservation of Antique Radio in Canada (SPARC) is based a couple of miles from my home here in Coquitlam, BC (about 15 miles east of Vancouver). SPARC (see their 'virtual museum' at <http://www3.telus.net/radiomuseum/>) has a large museum area open to visitors as well as extensive storage space for sets/spares and facilities for repair and restoration of cabinets and electronics. A visitor to the museum tours displays in areas set up for:

- Spark and early wireless, including a 'Carpathia Radio Room'
- West-coast marine radio history
- Military communications from 1914 through the 'Cold War'
- A working radio broadcast studio
- Domestic radios – an extensive display covering the development of radio technology including many crystal sets, TRF's, cathedrals, tombstones, tallboys, etc., many working, restored or in excellent 'original' condition (photo, below)
- Amateur radio from 1930 to 1980's
- Television
- Cable telegraph equipment from the Bamfield Cable Station (Vancouver Island) from 1902 to 1960's

The museum is run on a volunteer basis and holds one of the largest collections radio sets in North America, a large spares store and walk-in 'valve vault' stacked floor to ceiling (yes, I am a truly lucky man...). As I have mentioned in previous articles, the museum has several Eddystone sets, including the S.680X I restored last year.



Much of the museum's collection has been acquired by donation – often someone will just drive up to the door on a Sunday afternoon and unload 'junk' (sometimes aka 'treasure') from their car or truck for the museum to do what they can with. Of course some such donations really are junk – water-soaked and broken 1970's stereograms, 1960's TV sets with rats nests inside, unidentifiable pieces of test gear, medical or industrial electronics. A 'triage' system is therefore in place whereby learned volunteers assesses the donated items on arrival, with the lucky (eg. more unusual, exceptional or interesting) items being catalogued and entered into the museum's inventory, the rest being dismantled to remove useful parts

(eg. valves, knobs, speakers), any obviously hazardous materials (eg. asbestos) segregated and disposed appropriately, and the remainder of the carcass then also being segregated and disposed or recycled appropriately (eg. wood, metals, plastics, glass).



Occasionally, items of particular interest arrive at the door for example, a few months back three Racal RA117s showed up, and more recently a pristine HBR13C homebrew amateur bands receiver was brought in by Jim Corbett, VE7BKX, donated by George Abbott, VE7AAN. Unfortunately I was not present when this particular set was brought in, but noticed it sitting in the storage area when I was visiting

SPARC the following week – it was the Eddystone '898' drive unit that caught my eye of course (photo, below). On closer inspection, the set, complete with all its hand-wound coils was observed to be extremely well constructed and in excellent condition – it had obviously been cherished and well looked-after for its entire life. It was also provided with a package of the original paperwork that had been accumulated by its previous constructor/owner prior to, during and after its construction in 1965/1966. This included the chassis templates and details of the Eddystone '898' dial drive, as well as some notes on some 'quirks' the receiver exhibits, for example when operating on the higher frequency bands.



### The HBR Receiver

Homebrew receivers for the amateur bands have always been popular – the satisfaction of pulling in weak signals worldwide from a piece of kit that you have made yourself is difficult to describe – my first attempt was a crystal set when I was about 12 or 13 years old, followed by a single transistor set soon after, a three transistor regeneration set and a few years later graduating to constructing a G3TDZ receiver as part of a homebrew NBFM transmitter/receiver for 2m when I was around 18 and eventually using this as part of a homebrew 10GHz transmitter/receiver in my mid-20's, before I became distracted from radio for many years by career and family... The interest in receiver homebrew continues in the radio amateur community to the present day, though the level of complexity, technologies used (eg. digital frequency readout, software defined radio and the use of PICs) and construction techniques (eg. LSI chips and surface mount components) employed in many leading-edge current receiver designs would have been

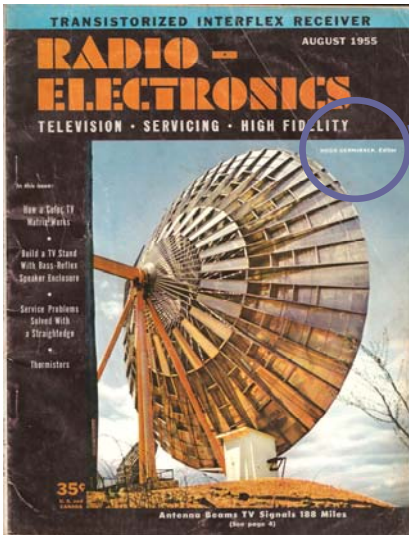

Above: A copy of 'Radio-Electronics' from the month yours truly became a harmonic...



Above: G3RKK's double-conversion homebrew sporting a '898'. Below: the G2DAF chassis, again fitted with the trusty '898' (a valve receiver project not for the 'faint of heart...')

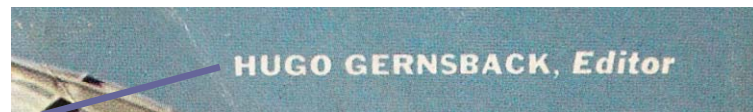
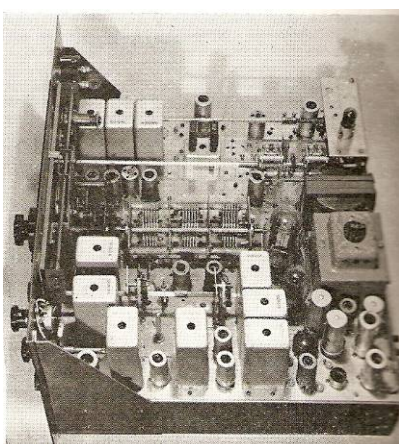

almost unimaginable at the genesis of the HBR receiver in the 1950's, though the well-known Hugo Gernsback, editor of 'Radio-Electronics' magazine in the US, often had some amazing insights into where things would go in the radio world – though not always correct...

As indicated above, homebrew receivers can vary greatly in level of sophistication - from a crystal set or simple one valve (or transistor)/single band circuit through to sets rivaling professional sets of the same era, with valve-counts in the teens (or more), covering several bands, having double or triple-conversion and having sophisticated filters, noise blankers, Q-multipliers etc. Construction of the more ambitious valve receiver designs, such as the G3RKK design using a commercially-available front end from 'Electroniques' to mitigate possible errors in constructing the front end of the set (so critical to achieving first-rate performance), the famous and superlative G2DAF receiver and the G3PDM (valve-transistor hybrid) design in the UK, all published in the RSGB 'Bulletin' and/or 'Radio Communications Handbook' were definitely not for the novice: a sound understanding of radio principals, construction techniques and alignment procedures was a pre-requisite for a successful outcome – after all, the parts for such receivers were not inexpensive and the investment in time for the constructor was huge. In the USA, the ARRL published the first 'HBR' receiver design by W6TC in the mid-late 1950's issues



of 'QST'. This receiver was a double-conversion design that simplified construction greatly by having plug-in coils rather than having a bandswitch, the latter 'convenience' item greatly adding to the complexity of the receiver wiring and therefore the potential for mistakes or poor layout affecting stability and performance of the receiver front-end (I would note that



it takes 30 seconds or so to change the coil set in the HBR13C – not a lot of time and effort unless you are 'band-hopping' very frequently, which most of us do not do).

Though circuitry, layout and construction arrangements differ for this class of homebrew set, the one constructional feature that these four particular receiver designs have in common is none other than the Eddystone Cat. No. 898 drive unit. Indeed it is sometimes specified in the text along with justification as to why it should be used, for example in the case of the G2DAF receiver description the text notes:

*“There is nothing worse than attempting to tune a selective receiver with a ‘lumpy’ drive mechanism or with one that has backlash in the gearing. A really first-class reduction drive – preferably one with a reduction of at least 100:1 – is essential. A readily available type is the Eddystone type 898 drive and dial assembly.”*

So, back to the HBR receiver, a variant of which was noted above as being recently donated to SPARC.

The excellent web site (home-page, right – spot the Eddystone '898' ...) by K5BCQ devoted to the HBR series of receivers (<http://www.qsl.net/k5bcq/HBR/hbr.html>) best summarizes the context of this receiver design and its variants thus:

*“Many radio amateurs, over the years, have enjoyed building/using their own transmitters/amplifiers built*



Bill McKay's (W7QBR) HBR Receiver in the 60s

## HBR Receiver Web Site

This site includes links to 100+ photos of various HBR Receivers ..... under construction, in use today, and in use years ago.

These are the tube type HBR-14, HBR-16, HBR-8, HBR-11, HBR-12, and HBR-13C receivers originally published in QST. Parts, and sometimes entire receivers, can be found at swapfests, on e-Bay, and through the various internet reflectors. There is an HBR Receiver reflector on Allan Waller's qsl.net server. The HBR Receiver Web Site has an abundance of information for those interested and details on how to join the HBR reflector. The "Hints & Kinks and Construction Notes" section includes useful data, applicable to ANY tube equipment.



from construction articles in *QST*, *CQ*, the *ARRL Handbook*, *RSGB Handbook*, *The Radio Handbook*, etc. The one homebrew item usually missing was a really good double-conversion CW/SSB/AM receiver with excellent sensitivity and selectivity that could be built/used with reasonable skills, at low cost, and with readily available tools. The answer in the late 50's and early 60's was the "HBR Receiver" and according to letters received by the original designer, Ted Crosby (W6TC-SK), the design proved very popular and several hundred were built worldwide. You probably think "...maybe great in 60's but why consider building/using one now ?" ....well, because it's a really good receiver (plenty of 50's and 60's tube gear is still in use on the air today), it's personally satisfying to build your own, and some of us just "wanted to build one" in the 60's....but never did. We now have the Internet to help locate unique parts and share

ideas....and, as indicated below, there are plenty of substitute parts available today to enable YOU to build one of these excellent HBR Receivers." ...

"There were several versions of these very popular homebrew receivers and several hundred were built worldwide. Most were built and worked very well, some had problems, some were never completed, all were probably interesting/fun experiences. The first was the HBR-14 published in the July 1957 *QST*, followed by the very popular HBR-16 in October 1959 *QST*, the HBR-8/11

in March/April 1963 *QST*, the HBR-12 in April 1964 *QST*, and the HBR-13C in October 1965 *QST*. There was also the "Deluxe HBR Receiver" (and matching SSB transmitter) in the 1967/68 (17th Edition) *Radio Handbook* by Bill Orr. In addition, several articles covering HBR Receiver improvements and add-ons (by Alex



Above: The HBR13C donated to the SPARC museum. Built in 1965/66, it came with an extensive set of documents used in its construction – some laid out in this photograph (though the coil winding tables were not included). Also shown here is the copy of *QST* (October, 1965) containing the article on this variant of the HBR receiver series (see photo at top of this page)



Above: Photo of the 'prototype' HBR13C receiver included in the documentation for the set donated to SPARC. Note differences in control layout, cabinet etc – but the '898' remains the same...

*Stewart (WA4ZNI) and Bill McKay (W7QBR) to name just two) were published in QST."*

The HBR13C is an amateur bands only, double-conversion superhet, with IF's of 1610kHz and 100kHz. Separate gain controls are provided for the RF stage, the second mixer and the two IF amplifiers (seems like over-kill, but it is noted that "...it is one of the features of the receiver. Normally the RF stage is run wide open, the mixer gain at

*about halfway, and the IF gain is advanced only enough to provide suitable signals at the detector. The RF stage gain is backed off only when a vey strong signal*

*attempts to take over the receiver.*"). Selectivity is provided by four 100kHz IF transformers, the two between the 2<sup>nd</sup> mixer and the first 100kHz IF amp being loosely capacitance-coupled (10pF). The IF bandwidth is noted as being 3kHz with steep 'skirts' (ideal for SSB reception and ok'ish for AM), though surprisingly no crystal filter is fitted for CW reception. Instead, for CW, reliance is put on the response curve characteristics being able to provide 'true single signal selectivity'<sup>1</sup>. The design is commented on as being exceptionally stable and with a high signal to noise ratio. The circuit is noted to use 'standard parts' throughout, with the exception of the plug-in coils, and to cost an estimated \$170 to build (in 1965), complete with valves, crystals and cabinet (and presumably the Eddystone '898'). Period notes accompanying the set (by WA4ZNI) note that "*The Eddystone dials are obtainable ONLY from British Radio-Electronics, Washington, D.C. See their ads in any issue of QST.*" The '13C incarnation of the HBR design included a product detector for SSB/CW reception and a stage of amplification at the first IF of 1610KHz. A 3.5MHz crystal calibrator is fitted to provide a reliable indication of the lower edge of the amateur bands covered by the set.

The HBR13C receiver donated to SPARC is a very good example. It does not follow the templates or layout shown in the prototype photographs exactly, as indeed it need not, but incorporates ideas and minor changes that the constructor thought appropriate or to suit components or materials 'in hand'. This is part of the 'poetic licence' and satisfaction of homebrewing, providing the constructor has the experience and knowledge to limit such changes to non-critical areas of the design and/or layout. The Eddystone '898' is front

<sup>1</sup> Defined in the HBR literature as "...the elimination of the audio image in code [CW] reception... you tune into a signal, go down to zero beat and find no beat note on the other side." It is commented that the 6db 'nose' of the receiver is such that the average S7 code signal can be taken as solid copy even when a similar signal is present only 250Hz away – quite an achievement without crystal filter(s).



and central, as it should be of course, a large S-Meter is located to its right and the various controls arranged roughly as in the prototype beneath and left of the '898' slide rule dial. Interestingly, none of the control functions are marked on the front panel – here is a receiver who's operator obviously knew it inside and out! Four amateur bands are marked-up on the '898' dial (photo on Page 6) covering 7.00 – 7.33MHz, 14.00 – 14.35MHz, 21.00 to 21.45MHz and 28.00 to 29.70MHz (wot, no 80 metres?....).

The set was briefly air-tested at SPARC and it pulled in several amateur stations on a short random-length wire on all bands. The controls function as expected and tuning using the '898' dial is a pleasure – it made the set feel like an Eddystone - easy to see why this dial is/was so popular.

I have included a copy of the full HBR13C receiver schematic and some of the accompanying circuit description, construction detail

and alignment notes as attachments to this article for those interested in taking a closer look at this receiver design, along with several photos of the HBR13C so kindly donated to the SPARC museum by George Abbott, VE7AAN. For more information on the HBR series of receivers, please refer to the K5BCQ website and the various references in QST below.

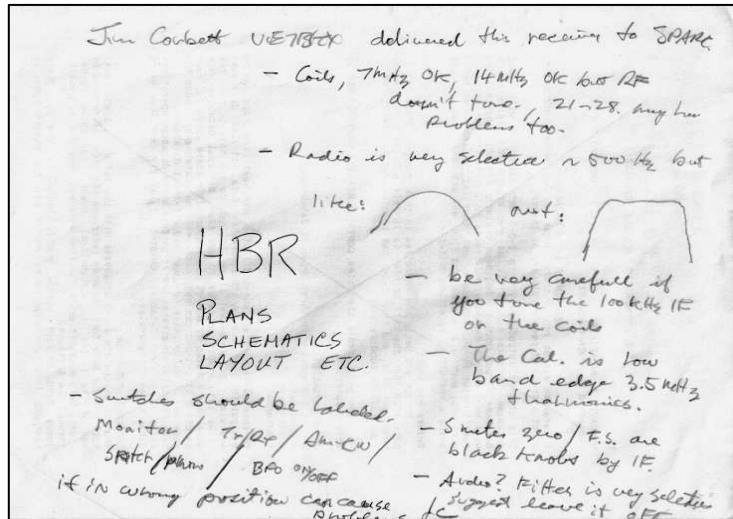

Above: Handwritten note accompanying the HBR13C donated to the SPARC museum

## Conclusion

Eddystone's reputation as a manufacturer of high-quality, sturdy and reliable components, together with their receiver's reputation for silky-smooth tuning obviously paid dividends in creating a demand for the '898'. Receiver designs such as the G2DAF and the HBR, transmitter VFO's, signal generators and many other pieces of equipment benefited (or were even designed around) this mechanism, which greatly enhanced the quality 'feel' and operating pleasure of the host equipment. Even Eddystone adapted this simplified version of their classic slide rule dial for use in their range of smaller sets such as the S.820 and S.870. This drive design continues to be a popular item decades after it ceased production – as both a collector item and for incorporation into newly-constructed equipment – a tribute to its quality, reliability and classic design simplicity.

73's

© Gerry O'Hara, G8GUH/VE7GUH ([gerryohara@telus.net](mailto:gerryohara@telus.net)), Vancouver, BC, Canada, January, 2008

**References**

**Websites:**

- <http://www.io.com/~nielw/hbr16/index.html>
- [http://s88932719.onlinehome.us/Boatanchors\\_Directory/Homebrew.htm](http://s88932719.onlinehome.us/Boatanchors_Directory/Homebrew.htm)
- <http://www.qsl.net/k5bcq/HBR/hbr.html>

**Handbook/Magazine Articles:**

- The 1967/68 17th Edition of 'The Radio Handbook' by Bill Orr (W6SAI) has a 16 page construction article on 'The Deluxe HBR Receiver' (and a matching SSB transmitter)
- Radio Communication Handbook, 4<sup>th</sup> Ed. RSGB, 1968, pp. 4.56 – 4.68, 10.104 – 10-108 (and insert circuit diagram)
- Various issues of QST magazine, ARRL, listed as follows on the K5BCQ website:

1957	Jul p.11 Ham-Band 14 tube Double Conversion Receiver HBR-14 (9 page article)
	Aug p.10 feedback
1958	Feb p.49 Technical Correspondence on the HBR-14
	Apr p.46 Technical Correspondence on the HBR-14
1959	Oct p.11 The HBR-16 Communications Receiver (8 page construction article)
	Nov p.32 Info on the type 1461 Tuning Capacitor
1960	Apr p.35 Notes HBR-16
	May p.44 feedback
	Jun p.62 HBR-16 Receiver in Retrospect
	Dec p.36 Using the 7360 in the HBR-16
	Dec p.45 Phone Reception
1961	Jun cover QSL cards from several HBR-16 builders
	Jun p.18 HBR with the Eddystone Dial (4 page HBR-16 by Alex Stewart)
	Jun p.21 HBR-16 Product Detector
1962	Jun p.59 6BY6 Product Detector
1963	Jan p.36 Added Versatility for the HBR-16 (6 page HBR-16 by Bill McKay)
	Feb p.15 The Ubiquitous HBR (1 page of photos of Hemenway's HBR-16)
	Mar p.11 The HBR-8 Communications Receiver (10 page construction article)
	Mar p.75 feedback
	Apr p.37 The HBR-8 Becomes the HBR-11 (6 page construction article)
	Apr p.42 Modifying the HBR-11 for AM Phone
	May p.19 feedback
	Jun p.168 feedback

1964	Apr p.35 The HBR-11 to Date [HBR-12] (6 page construction article)
	May p.23 feedback
	Jul p.59 Tech Correspondence
1965	Oct p.11 HBR Developments [HBR-13C] (8 page construction article)
1967	Jun p.74 Parasitics in the HBR Receiver
	Jul p.42 Audio Selectivity for the HBR
1969	Feb p.20 T-Notch for the HBR

**Attachments**

- HBR13C receiver circuit diagram (3 pages) and construction templates
  - G2DAF (G.R.B. Thornley) receiver circuit diagram (Rad. Com. Hbk. p. 4.63)
  - G3PDM (P.G. Martin) receiver circuit diagram (Rad. Com. Hdk. p. 10.106 )
- (compare the above to Eddystone communication receiver circuits of the same period – you will note they have comparable complexity with Eddystone’s professional models!)
- Eddystone Date Sheet No. 124 (2 pages)
  - The '898' mounting template
  - Selection of construction notes for the HBR13C receiver



Above: An above-chassis view into the HBR13C – note the 40 metre coil set is fitted here (L1. L2, and L3). The Eddystone '898' can be seen coupled to the tuning gang via a Millen flexible coupling

Winding the coils for a receiver (and getting it right!) can be a daunting prospect – the 'Q' of the coils can significantly affect the receiver performance and take it from mediocre to excellent (or vice-versa). Right: three of the four coil sets from the HBR13C. Below: location of the plug-in coils in the HBR13C front-end circuitry

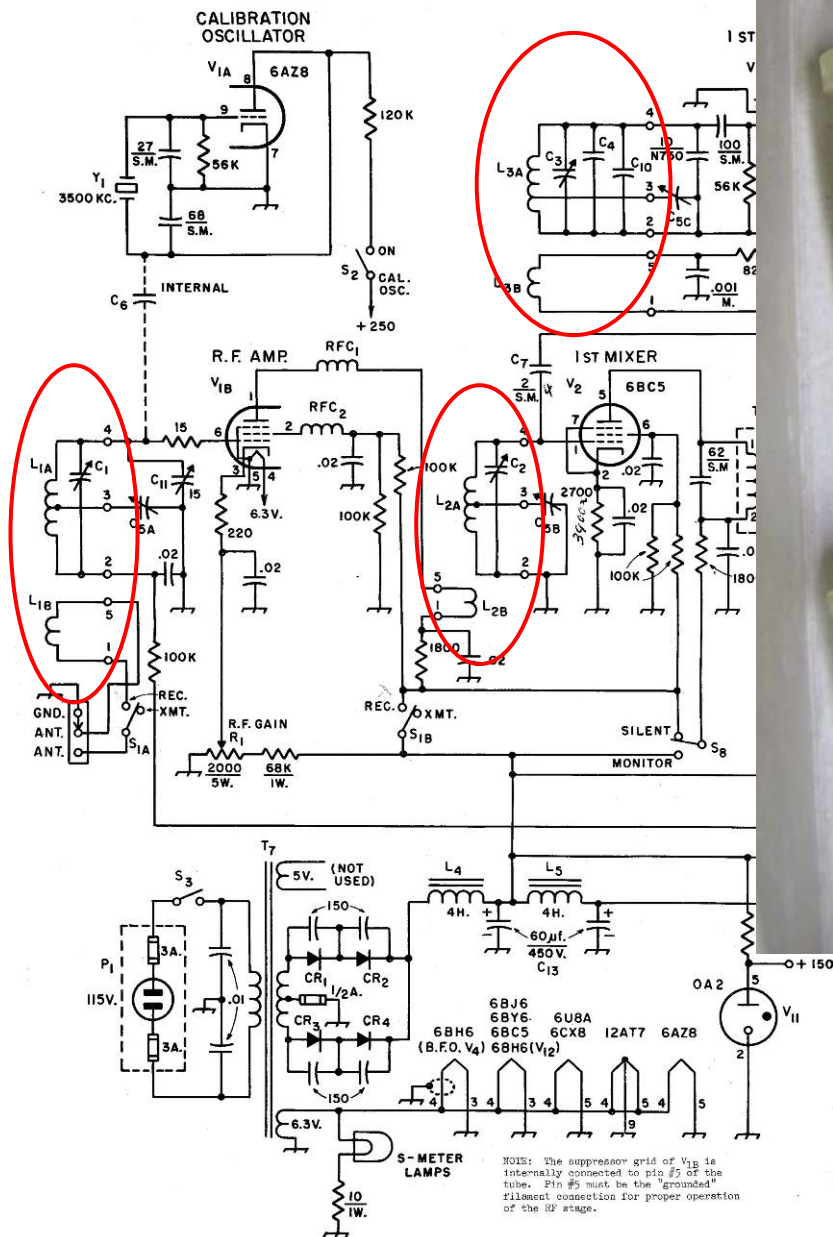

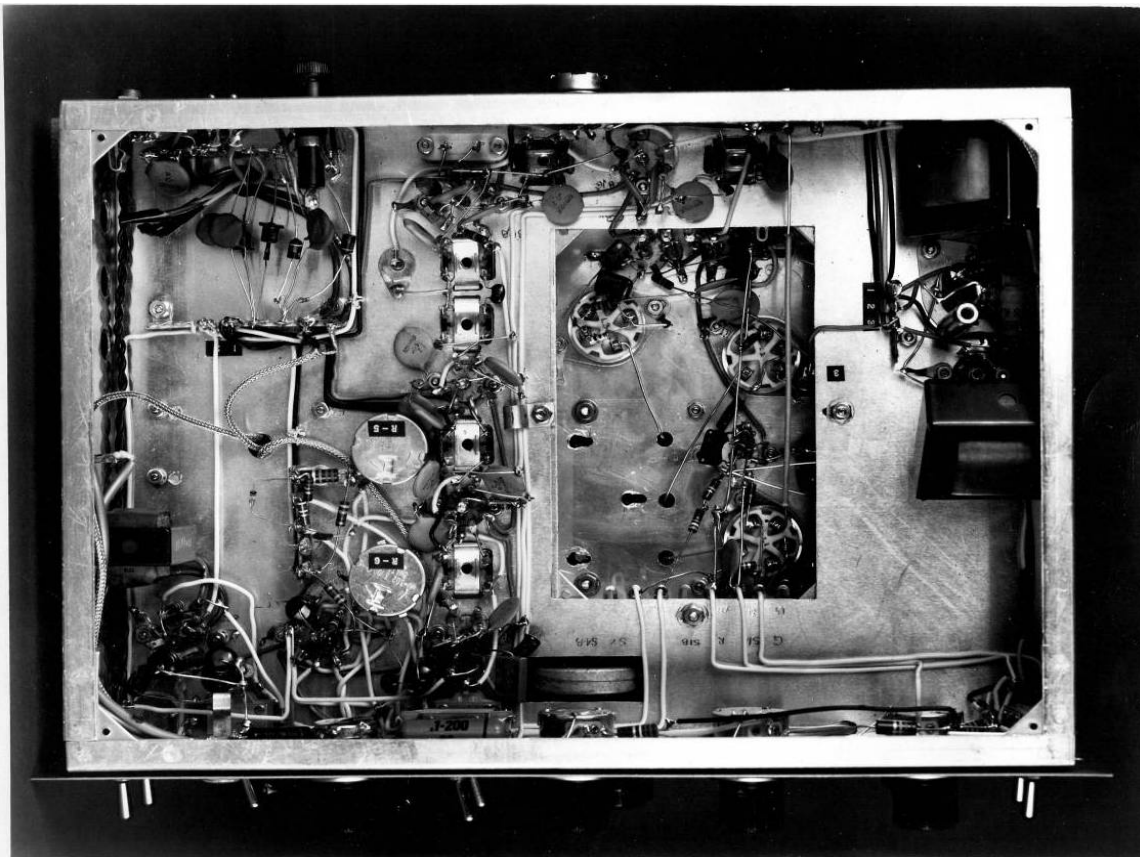
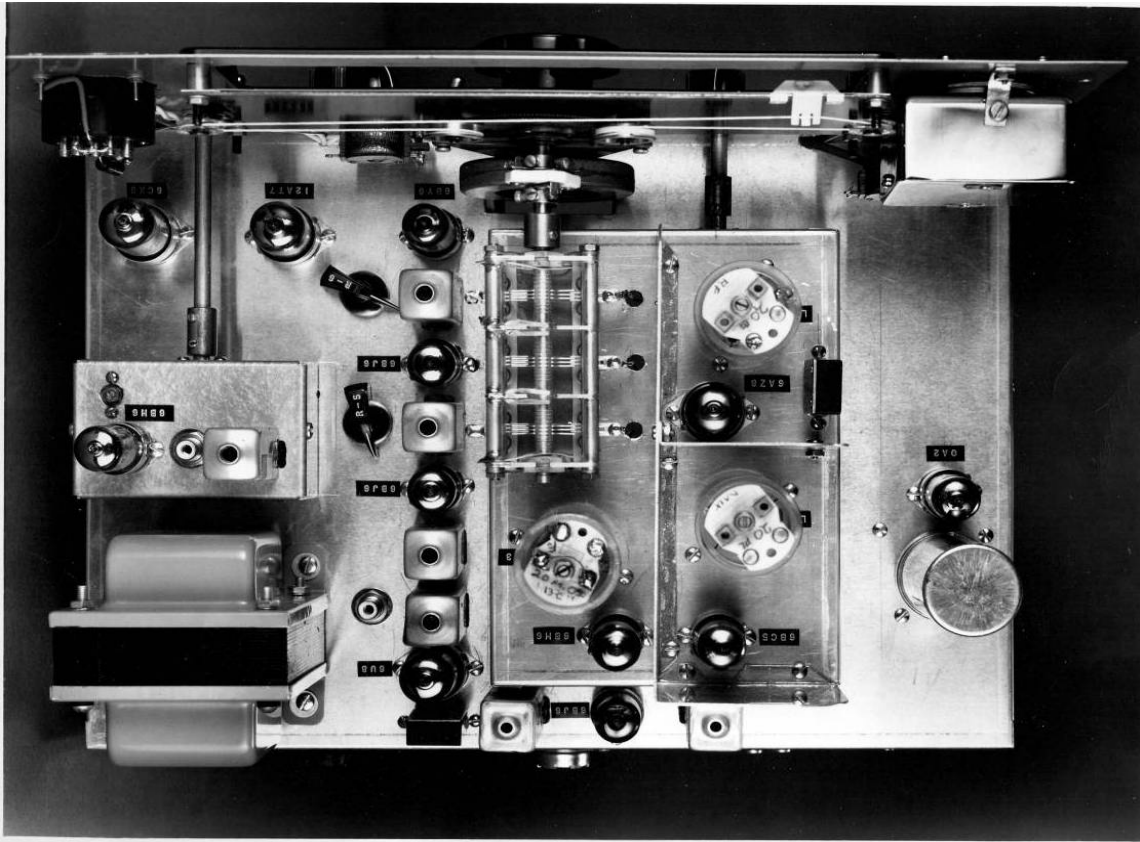

Above and below chassis views of the prototype HBR13C (note differences on the above chassis view here compared to the version donated to SPARC as shown on page 11)



Above: The HBR13C – not a bad looker for 43 years young - the Eddystone implant helps a lot of course... Maybe it would help more if we thought of the set as being the ultimate modification of an Eddystone part rather than an Eddystone part fitted into an 'alien' receiver?

## GEARED SLOW-MOTION DRIVE ASSEMBLY

Cat. No. 898

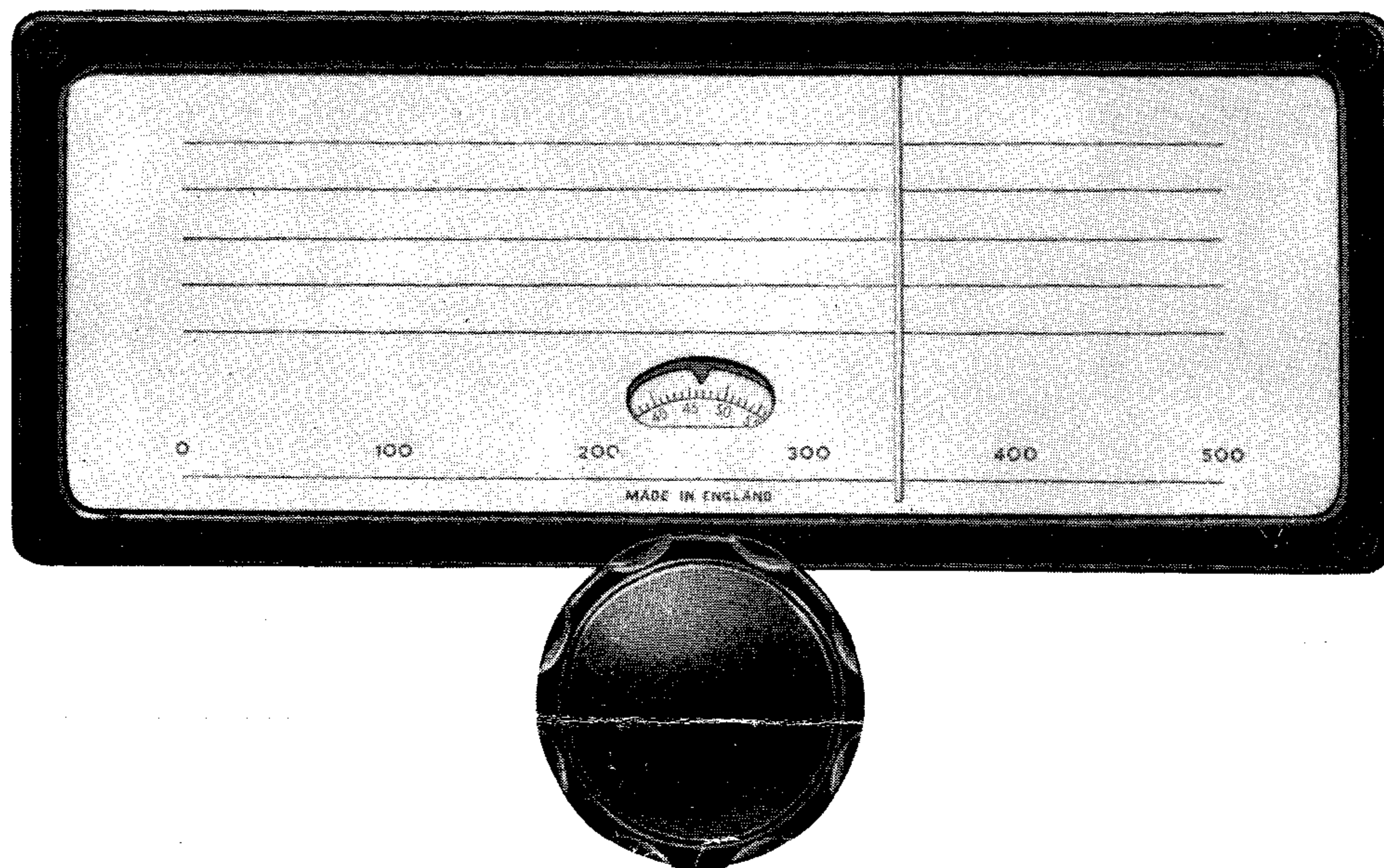

A high grade assembly designed for instrument applications. The movement is gear-driven and flywheel loaded, giving a smooth, positive drive, with a reduction ratio of 110 to 1.

The pointer has a horizontal travel of 7 inches. A circular vernier scale, marked over 100 divisions, rotates five times for one traverse of the pointer, and, read with the "100" scale on the dial, provides a total of 500 divisions. The dial has five lines to take calibration markings.

A diecast escutcheon, finished glossy black, is supplied and the assembly is complete with perspex window, knob, fixing screws, and mounting template. It is suitable for mounting on metal or wooden panels up to 7 mm. thick. Overall external dimensions are  $9\frac{3}{16}$ " (23.34 cms.) by  $5\frac{3}{4}$ " (14.6 cms.). Weight is approximately 1 lb. 14 ozs. (.85 kilogrammes).

J 959 Printed in England

## STRATTON & CO., LTD.

EDDYSTONE WORKS : BIRMINGHAM 31 : ENGLAND  
TELEPHONE: PRIORY 2231-4 TELEGRAMS: STRATNOID, BIRMINGHAM

# EDDYSTONE

## SLOW MOTION GEAR-DRIVE ASSEMBLY

Cat. No. 898

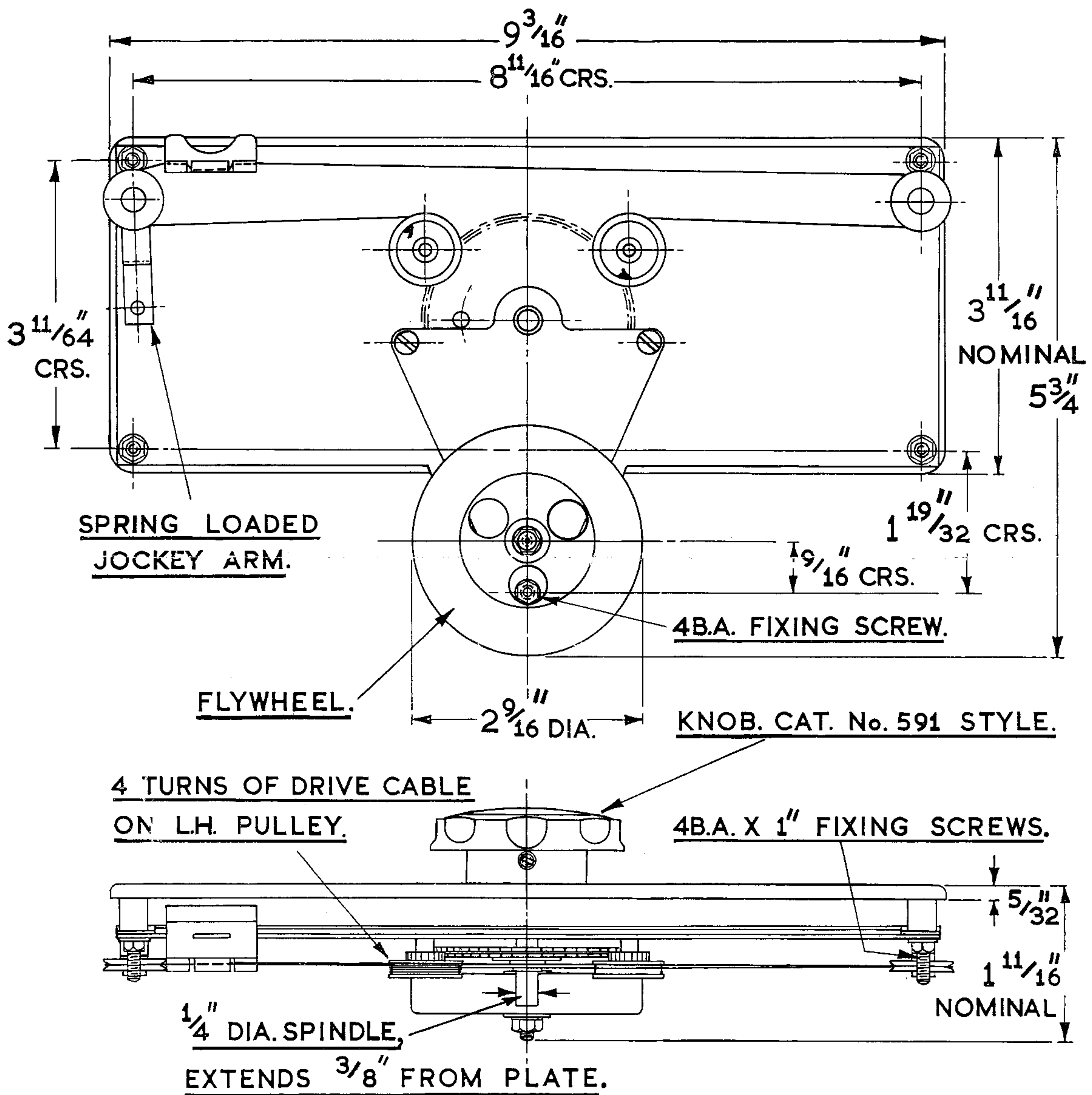



# EDDYSTONE RADIO

TRUE TO SCALE MASTER CUTTING TEMPLATE.

FOR MOUNTING "898" DRIVE UNIT.

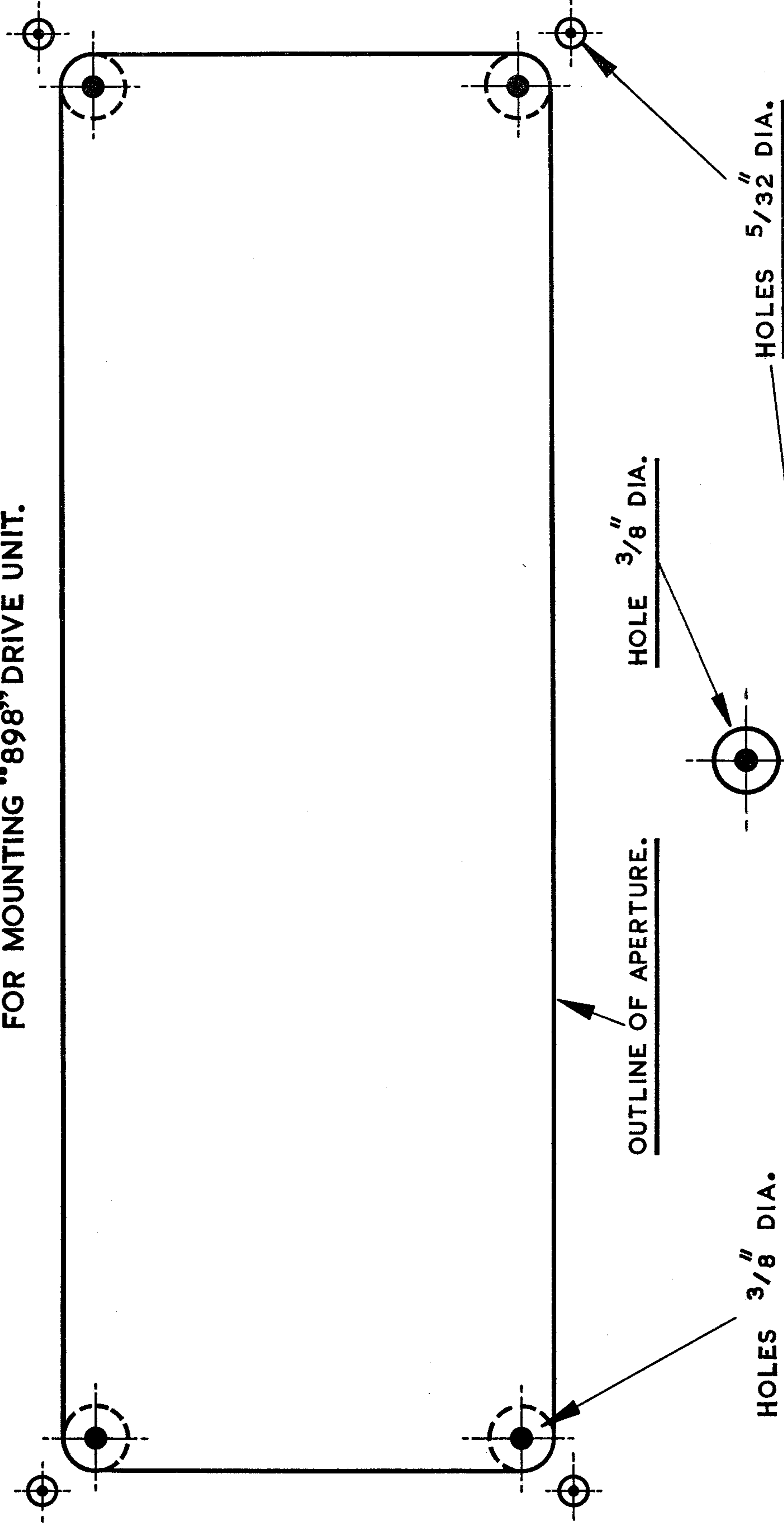

SCREW USED IN THIS POSITION, TO BE CUT TO LENGTH TO SUIT PANEL THICKNESS. (I.E. TO CLEAR FLYWHEEL).

**CALIBRATION  
OSCILLATOR**

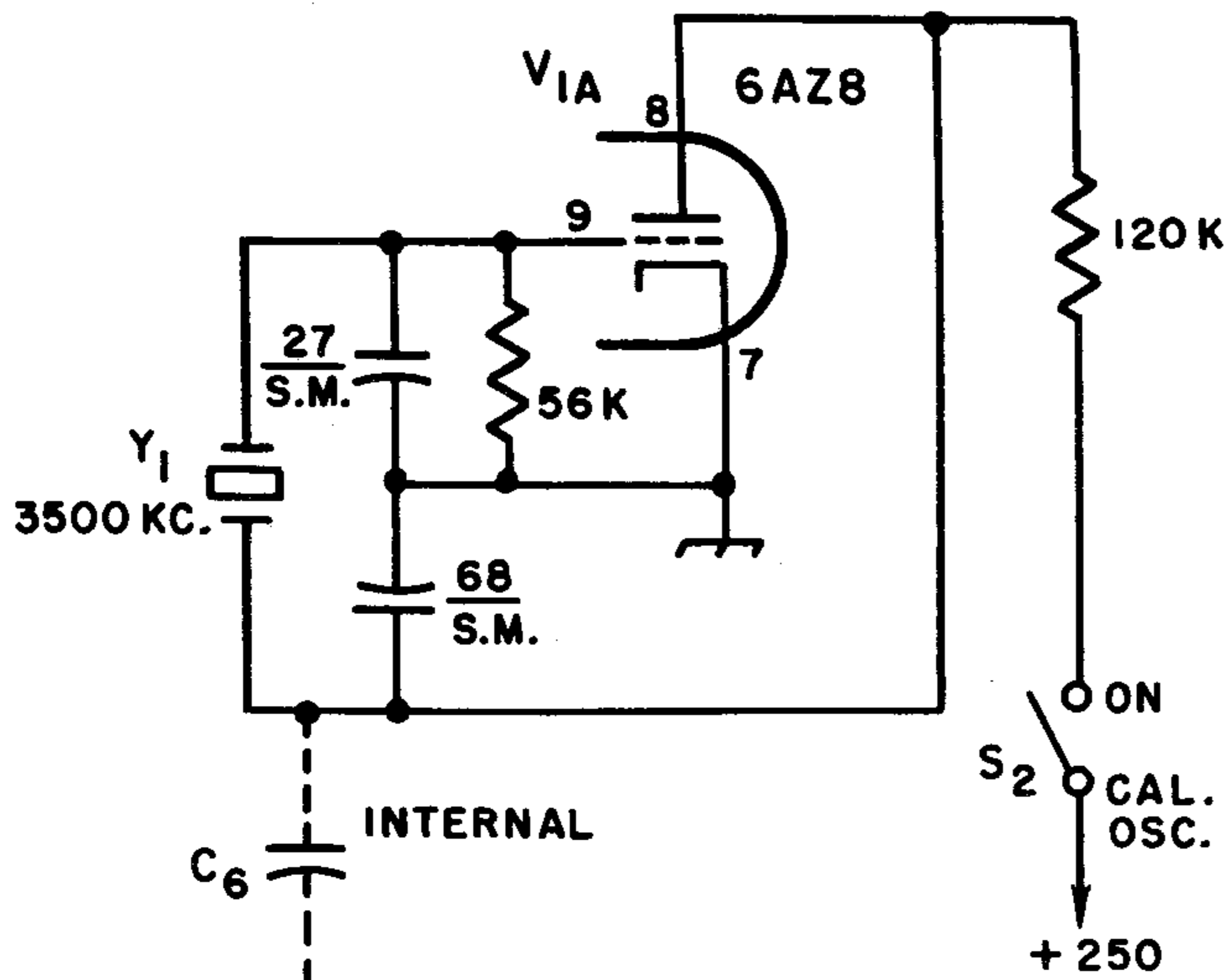

**1 ST OSCILLA**

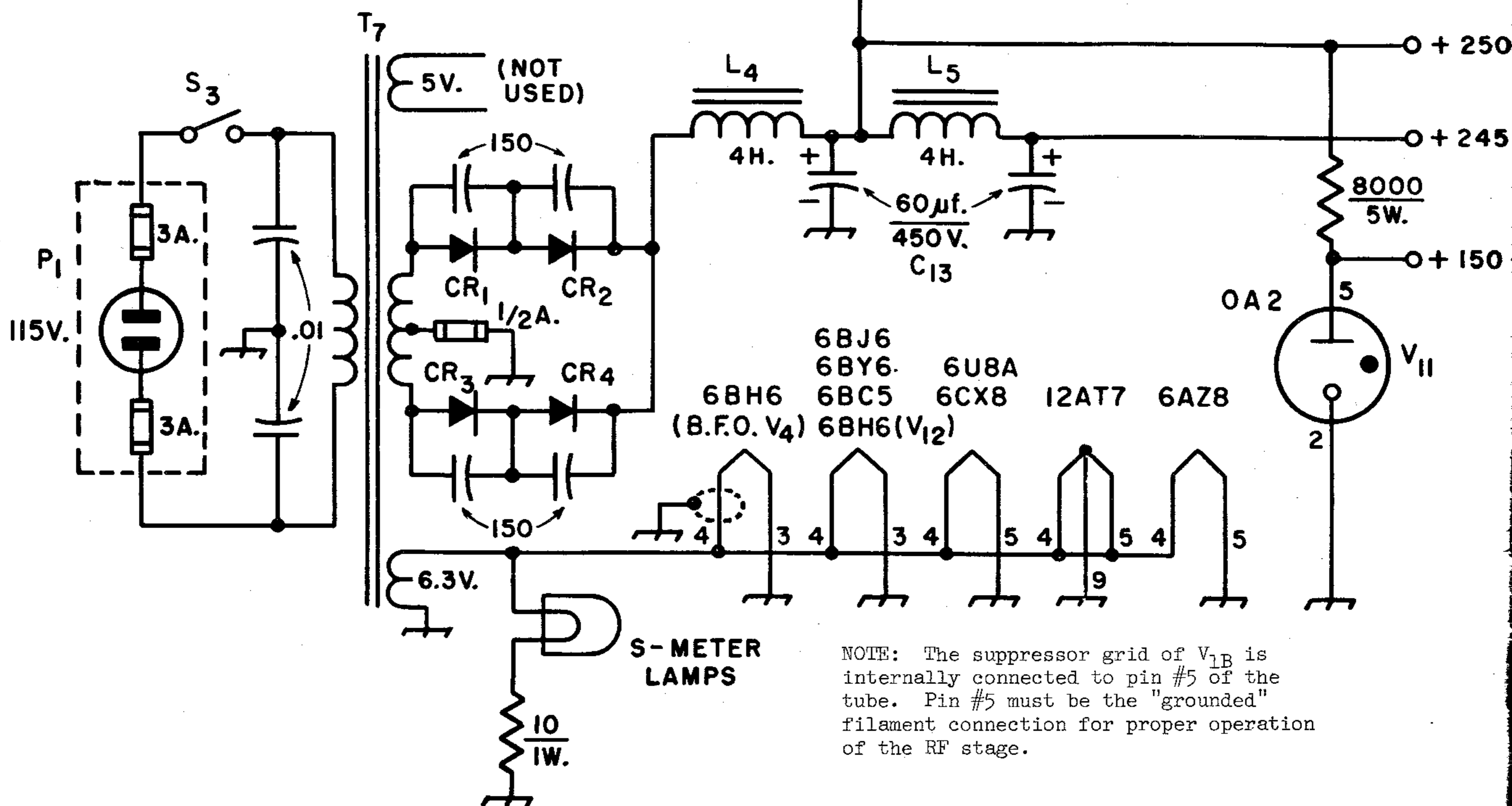
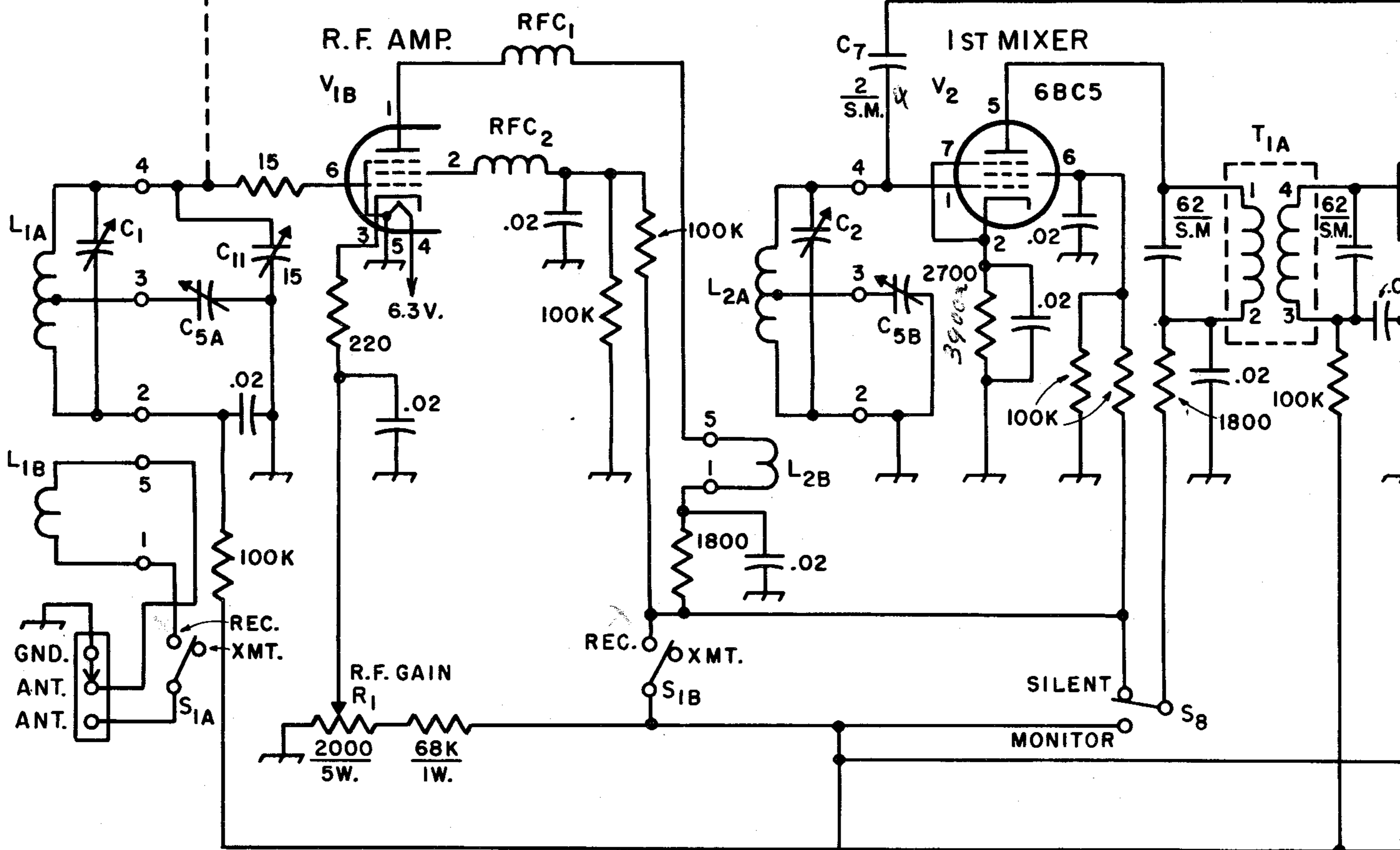
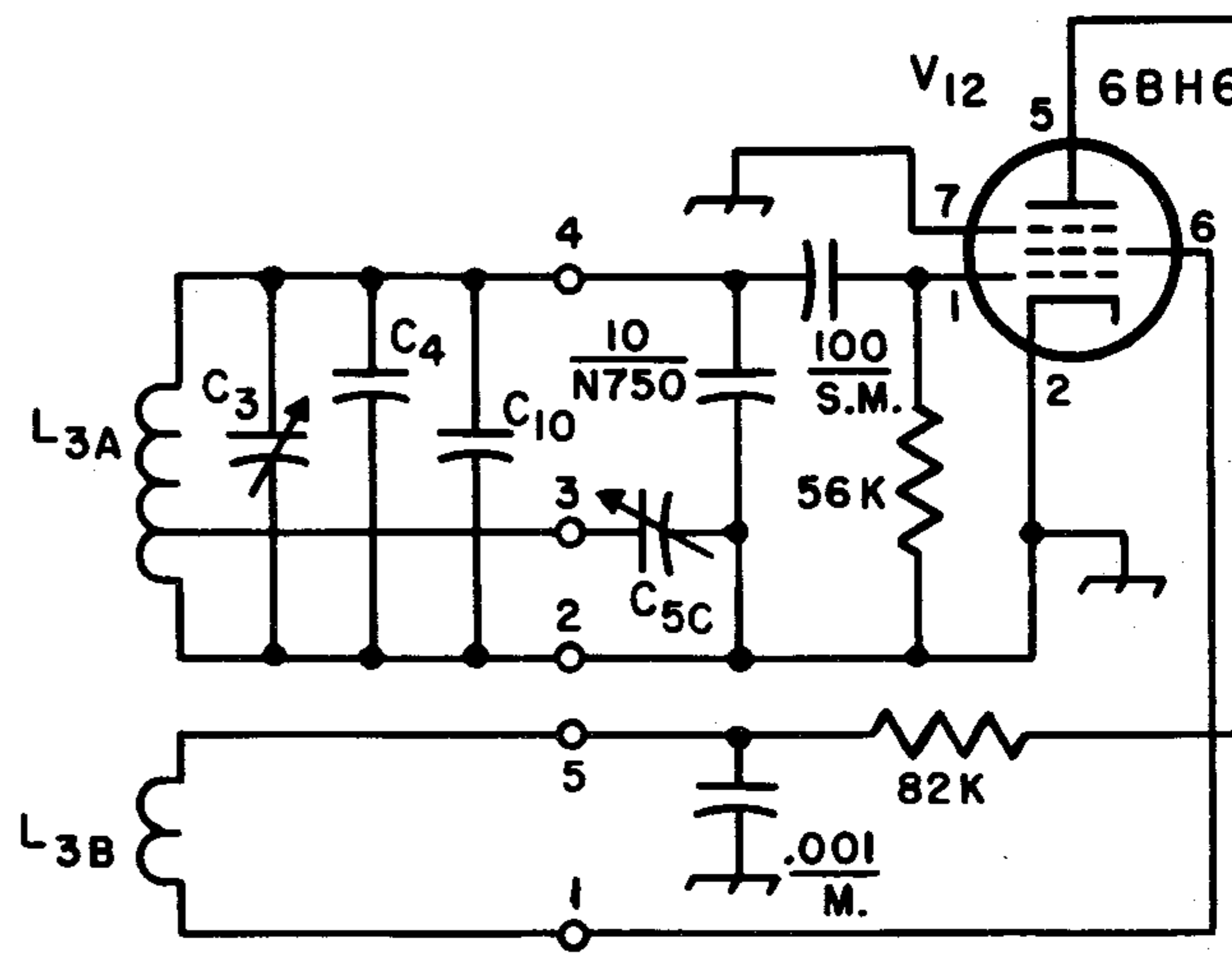

NOTE: The suppressor grid of V<sub>1B</sub> is internally connected to pin #5 of the tube. Pin #5 must be the "grounded" filament connection for proper operation of the RF stage.

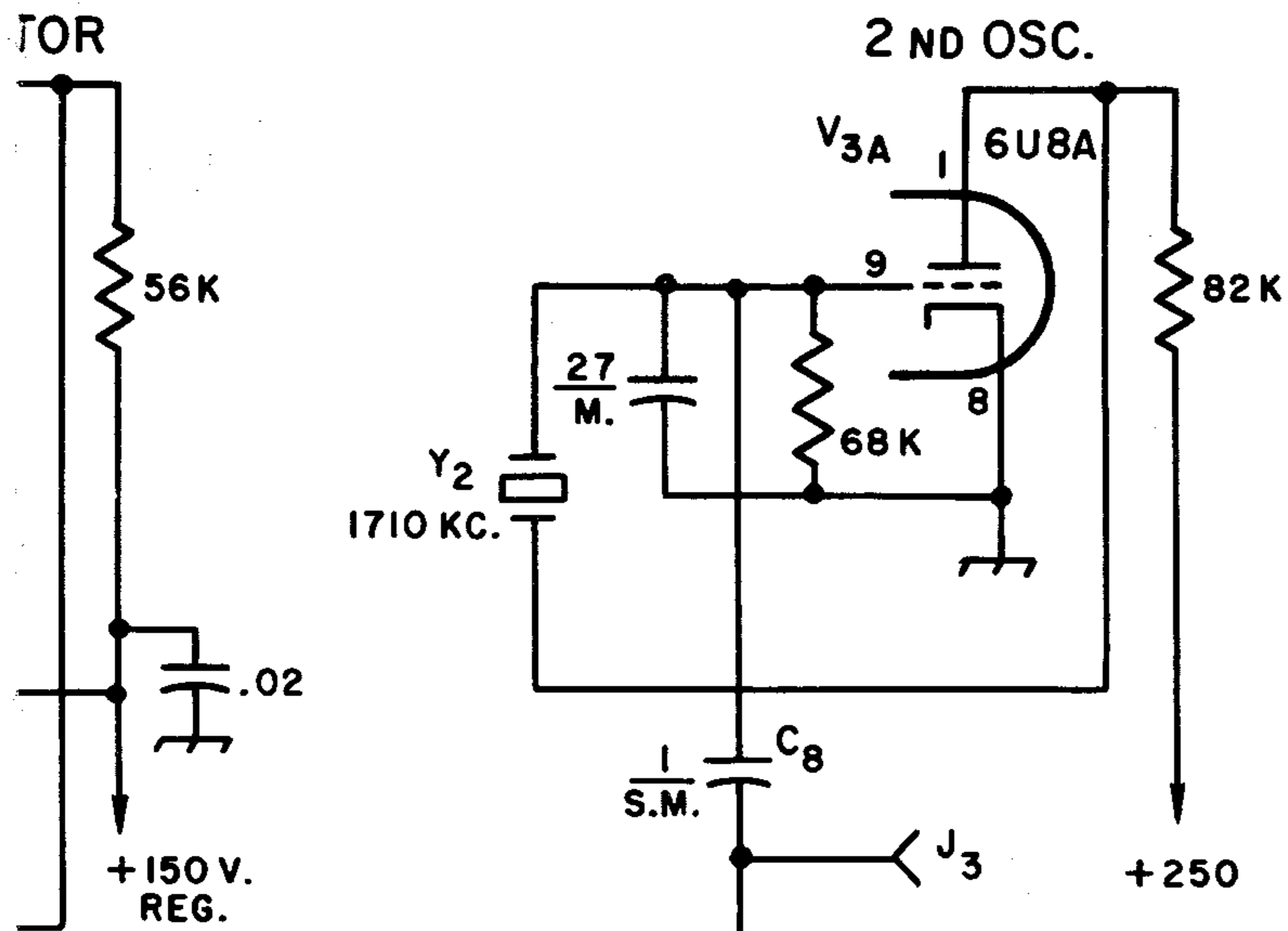

EXCEPT AS INDICATED, DECIMAL VALUES OF CAPACITANCE ARE IN MICROFARADS ( $\mu\text{f.}$ ); OTHERS ARE IN PICO FARADS ( $\text{pf.}$  OR  $\mu\mu\text{f.}$ ); RESISTANCES ARE IN OHMS; K = 1000

Fixed capacitors are ceramic except where marked M (mica), SM (silver mica), or P (paper tubular). Inexpensive "Mylar" capacitors may be substituted for the 200/400 v. paper tubulars. When paper tubulars are grounded, the "outer foil" is the grounded end.

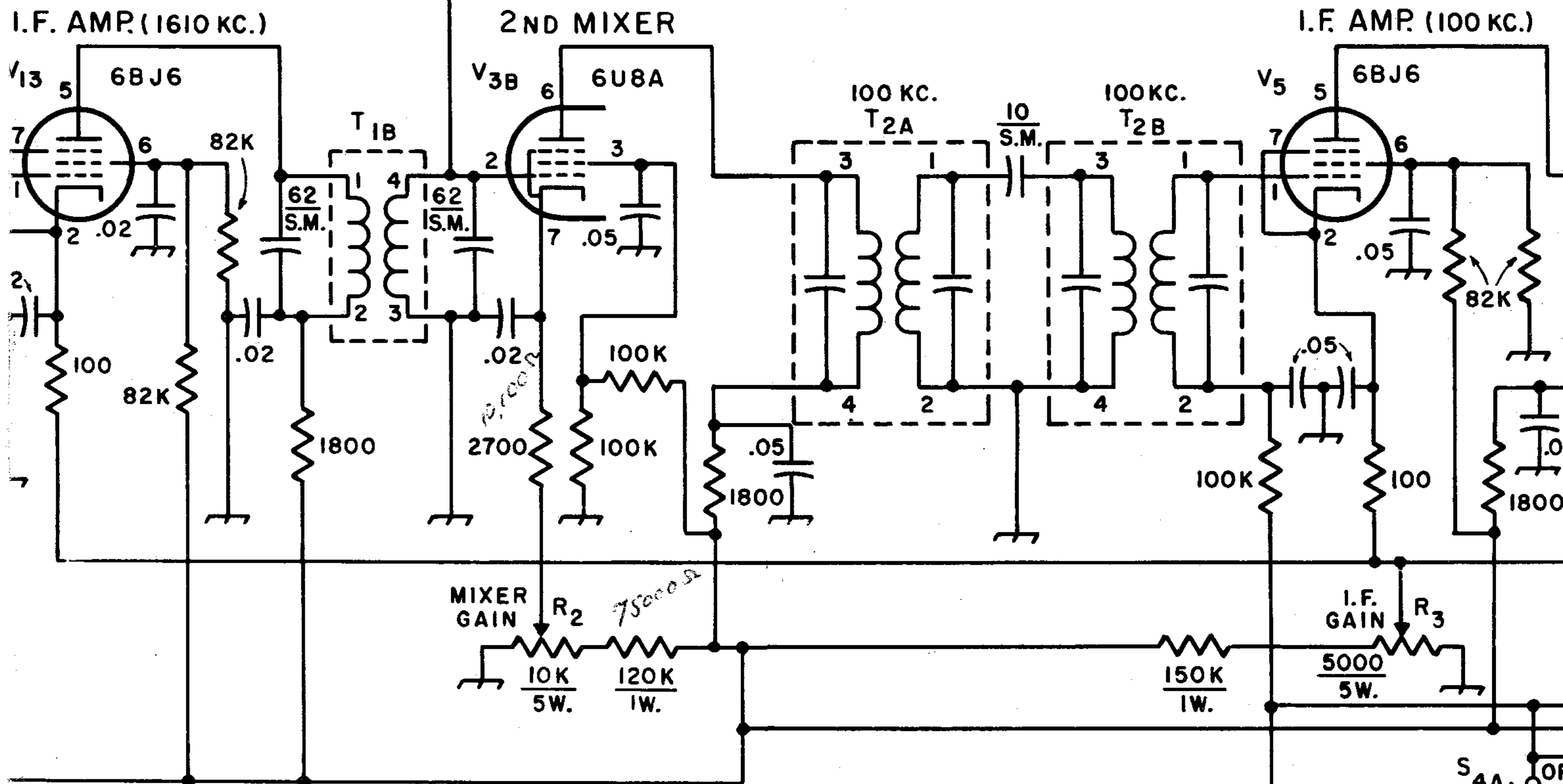

REGULATED

# HBR-13C

A modified version of the HBR-11/12 by Ted Crosby - W6TC

Alexander Stewart - WA4ZNI From Oct., '65 QST  
916 Croton Drive Alexandria, Virginia (corrected)

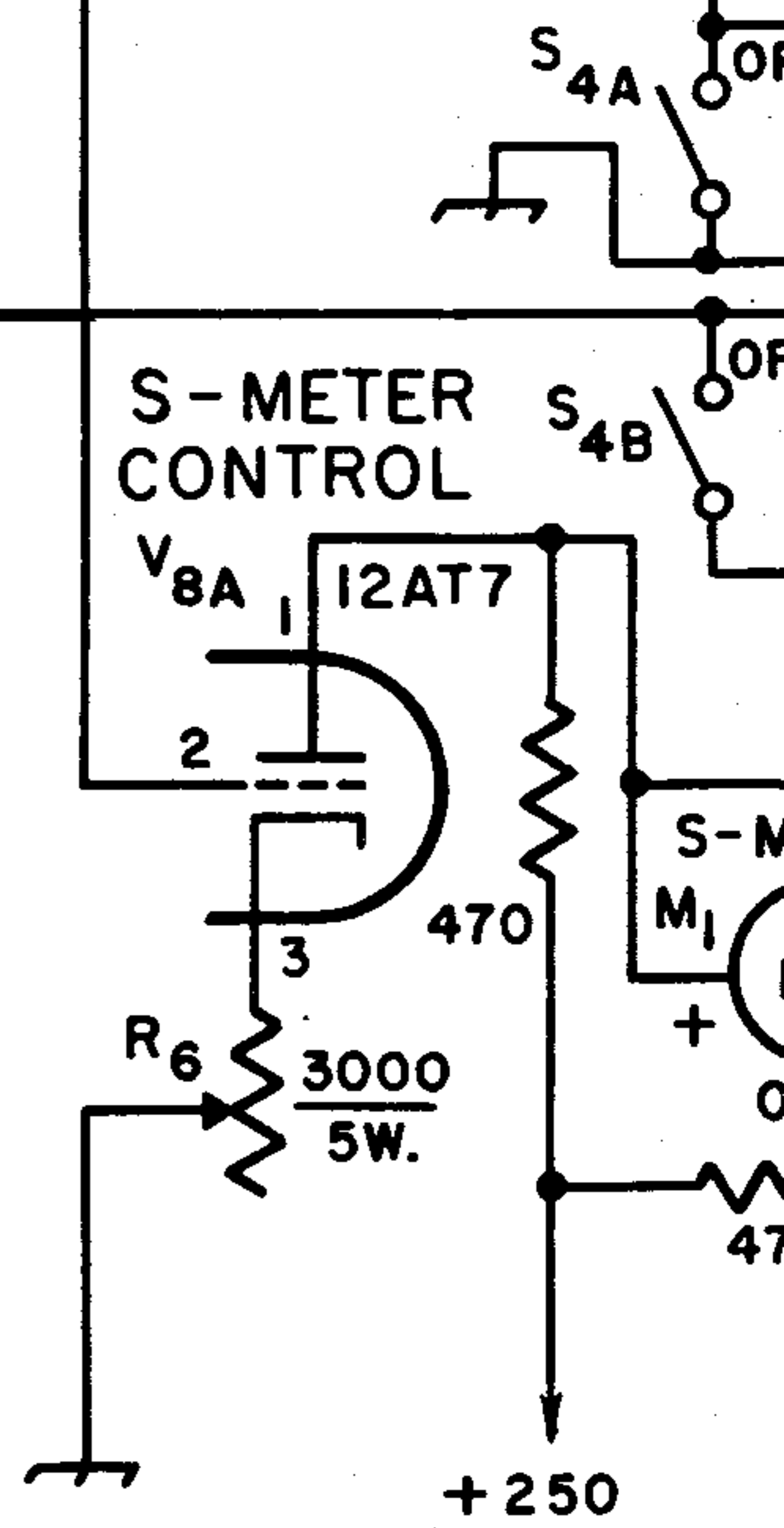

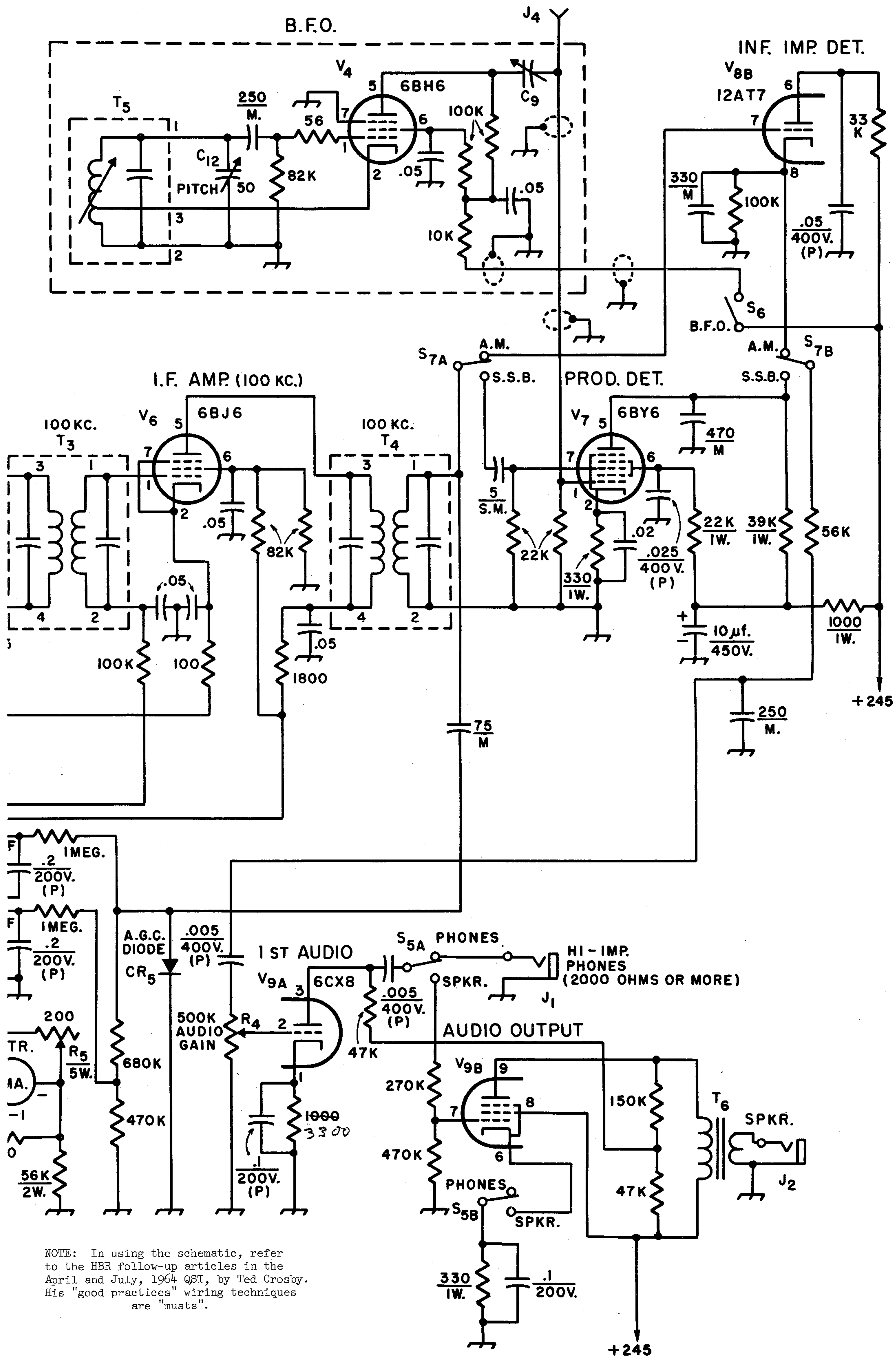

NOTE: In using the schematic, refer to the HBR follow-up articles in the April and July, 1964 QST, by Ted Crosby. His "good practices" wiring techniques are "musts".

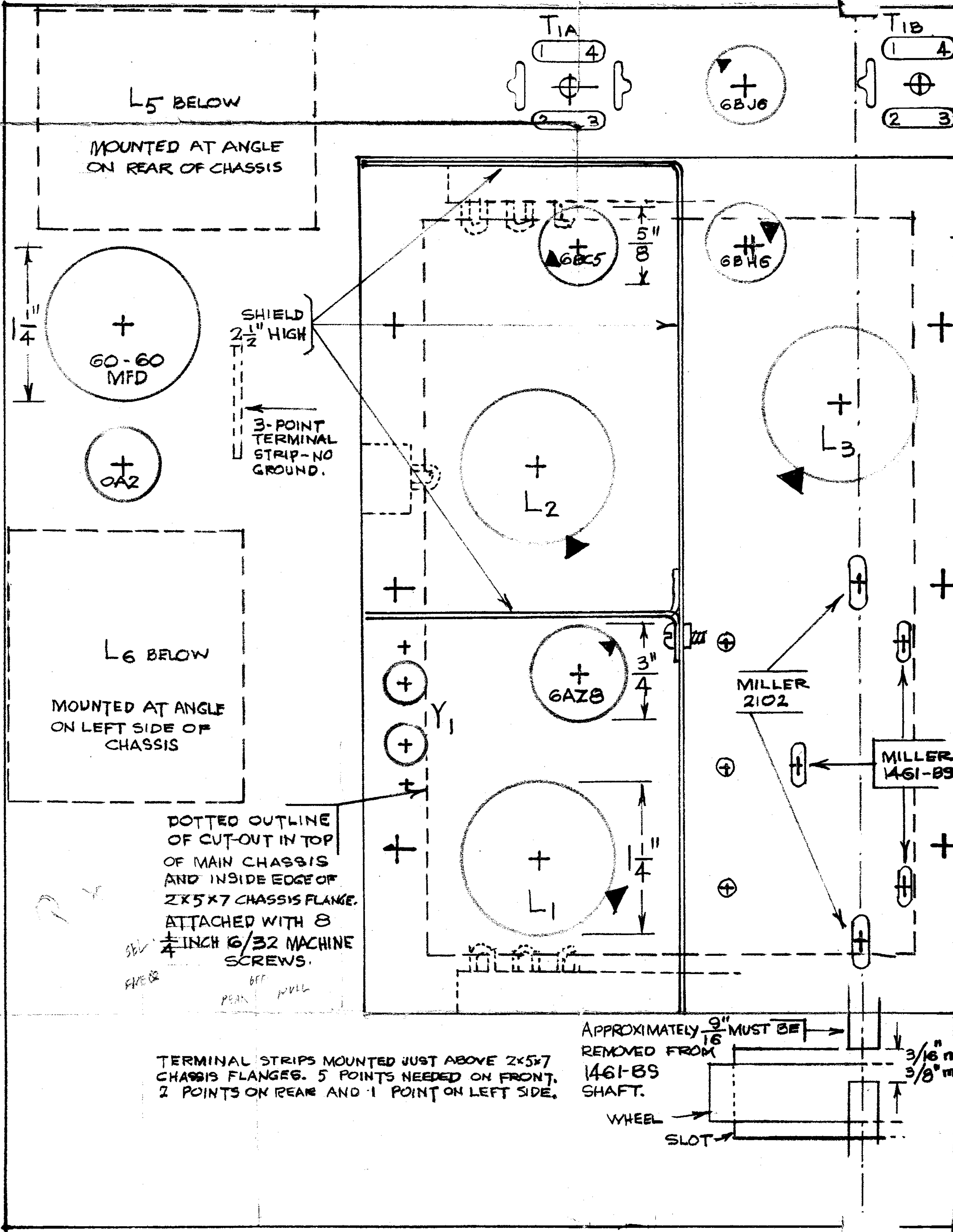

L5 BELOW

MOUNTED AT ANGLE ON REAR OF CHASSIS

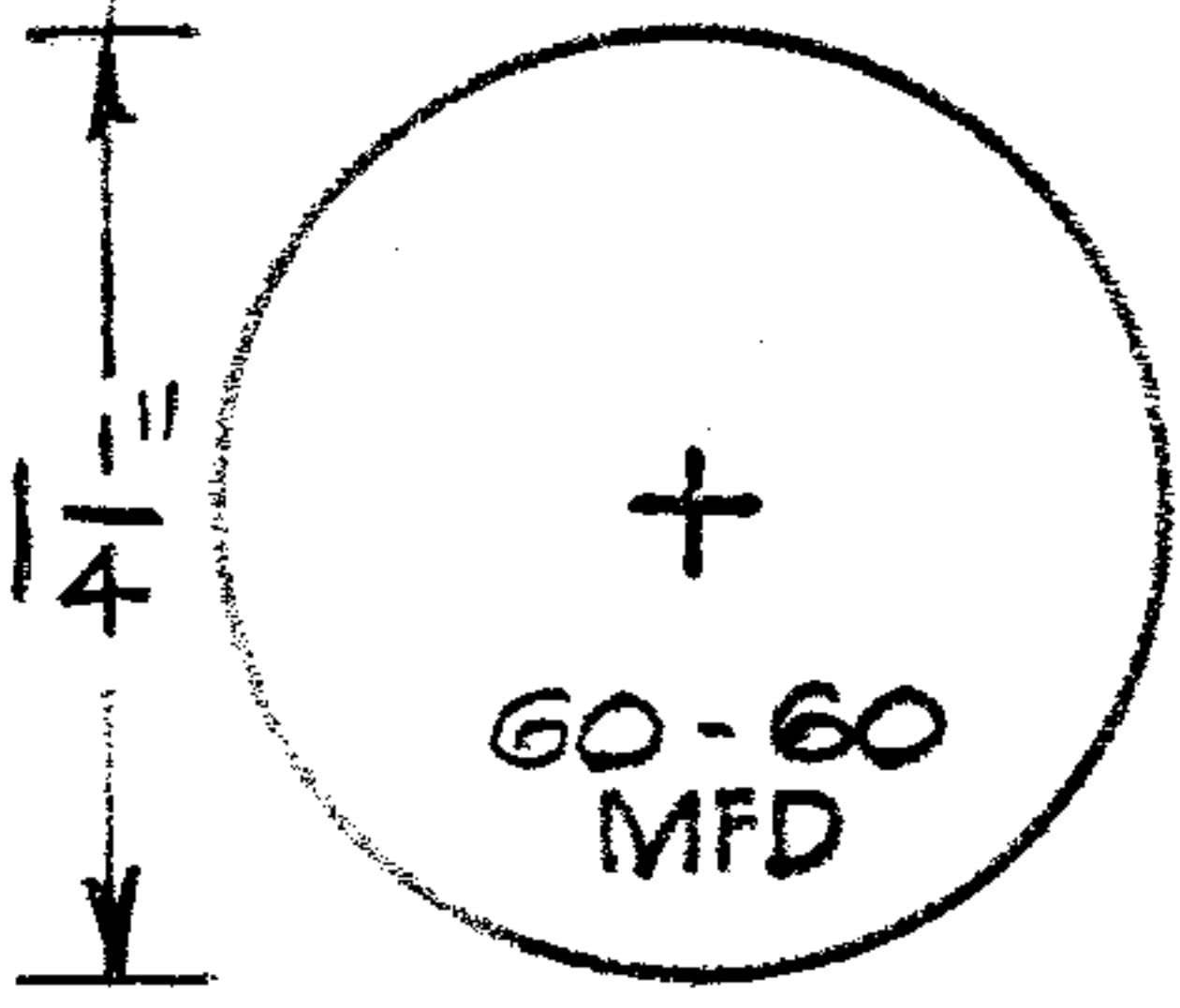

SHIELD 2 1/2" HIGH  
3-POINT TERMINAL STRIP-NO GROUND.

L6 BELOW  
MOUNTED AT ANGLE ON LEFT SIDE OF CHASSIS

DOTTED OUTLINE OF CUT-OUT IN TOP OF MAIN CHASSIS AND INSIDE EDGE OF 2X5X7 CHASSIS FLANGE. ATTACHED WITH 8 1/4 INCH 16/32 MACHINE SCREWS.

TERMINAL STRIPS MOUNTED JUST ABOVE 2X5X7 CHASSIS FLANGES. 5 POINTS NEEDED ON FRONT, 2 POINTS ON REAR AND 1 POINT ON LEFT SIDE.

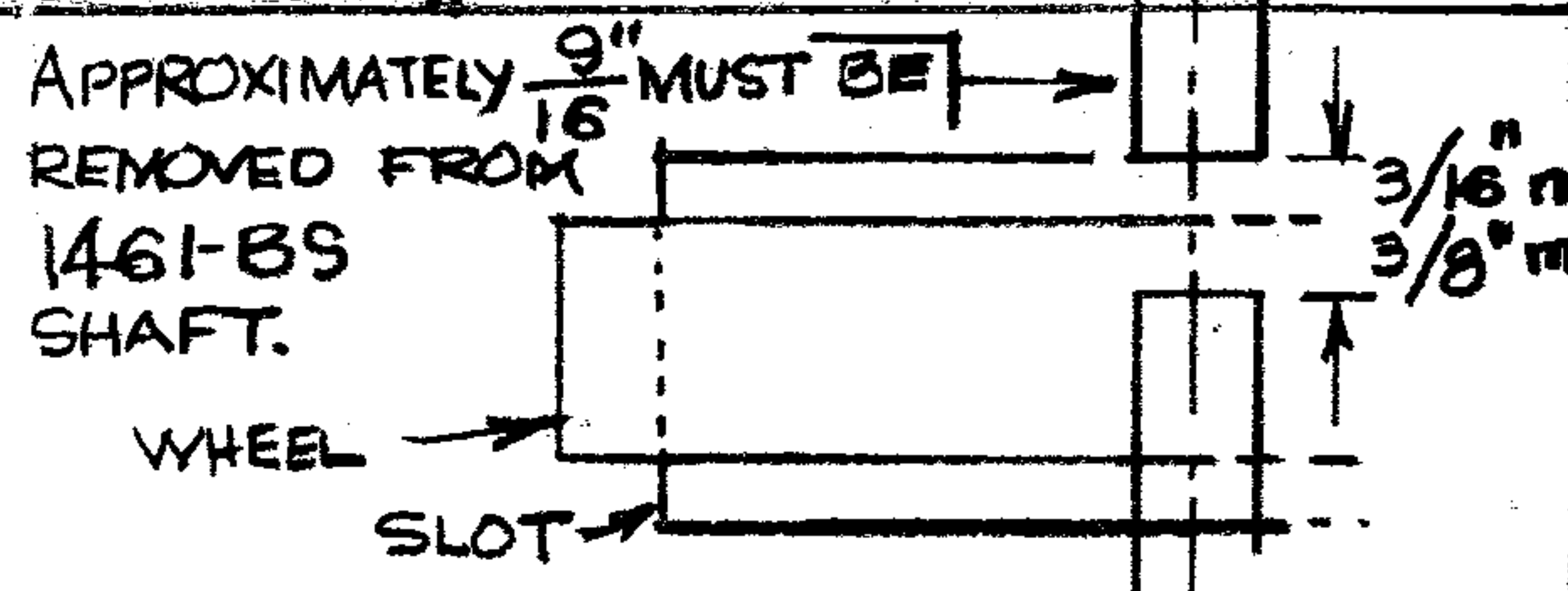

TOP OF CH

S8  
S1

SPKR9 1-2  
R1

C11  
R2

C5  
R3

"A"

HOLE FOR ADS FROM T7.

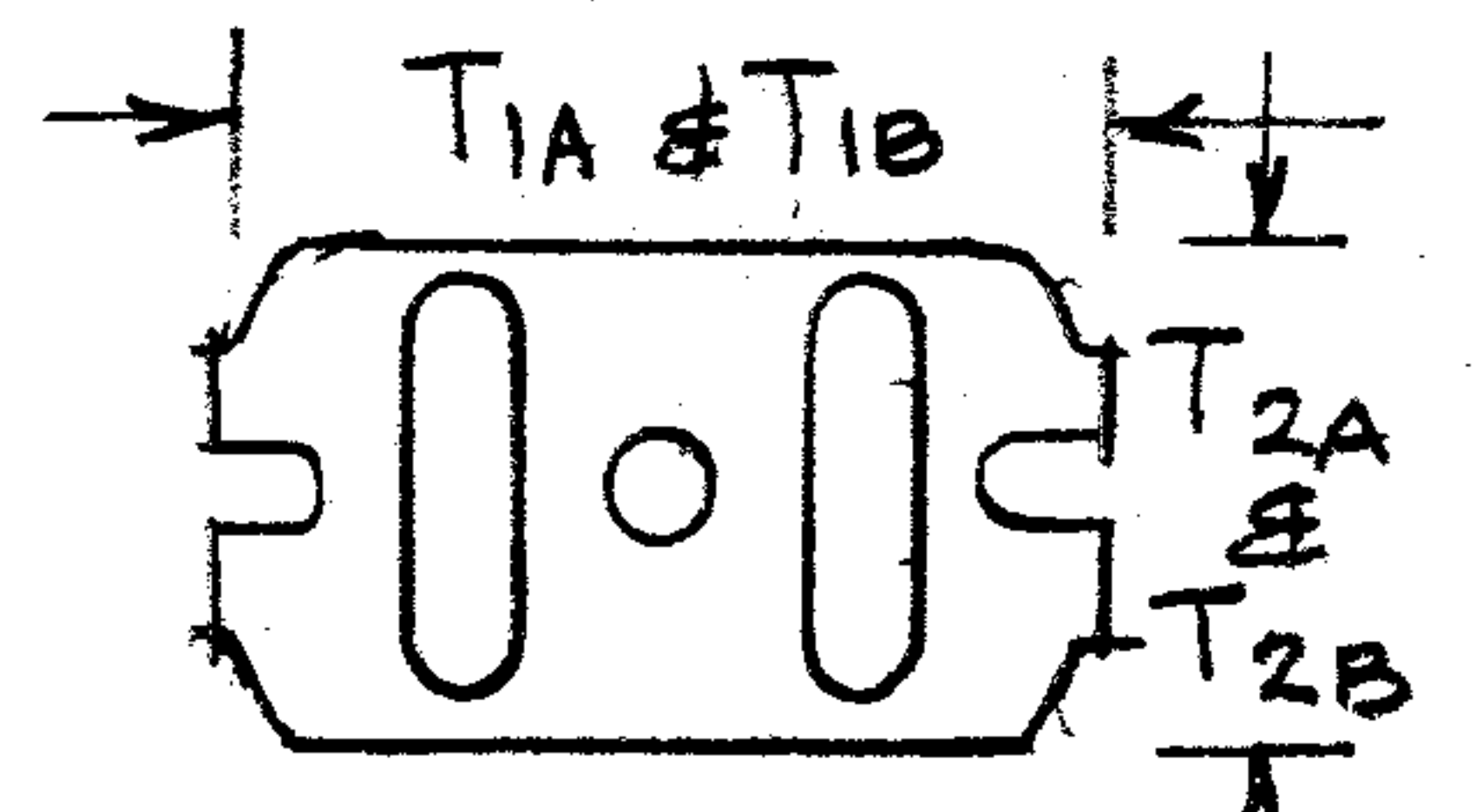
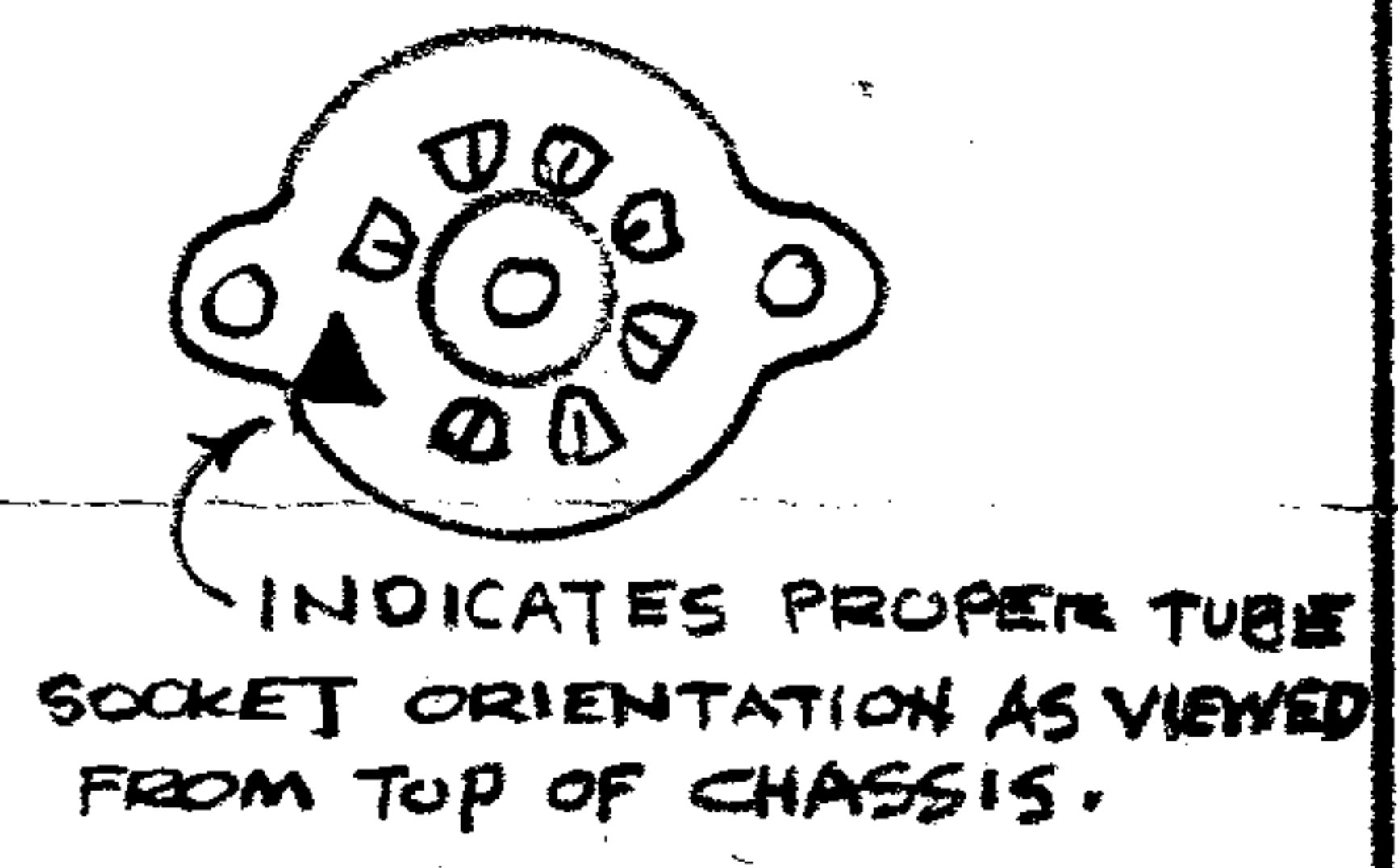
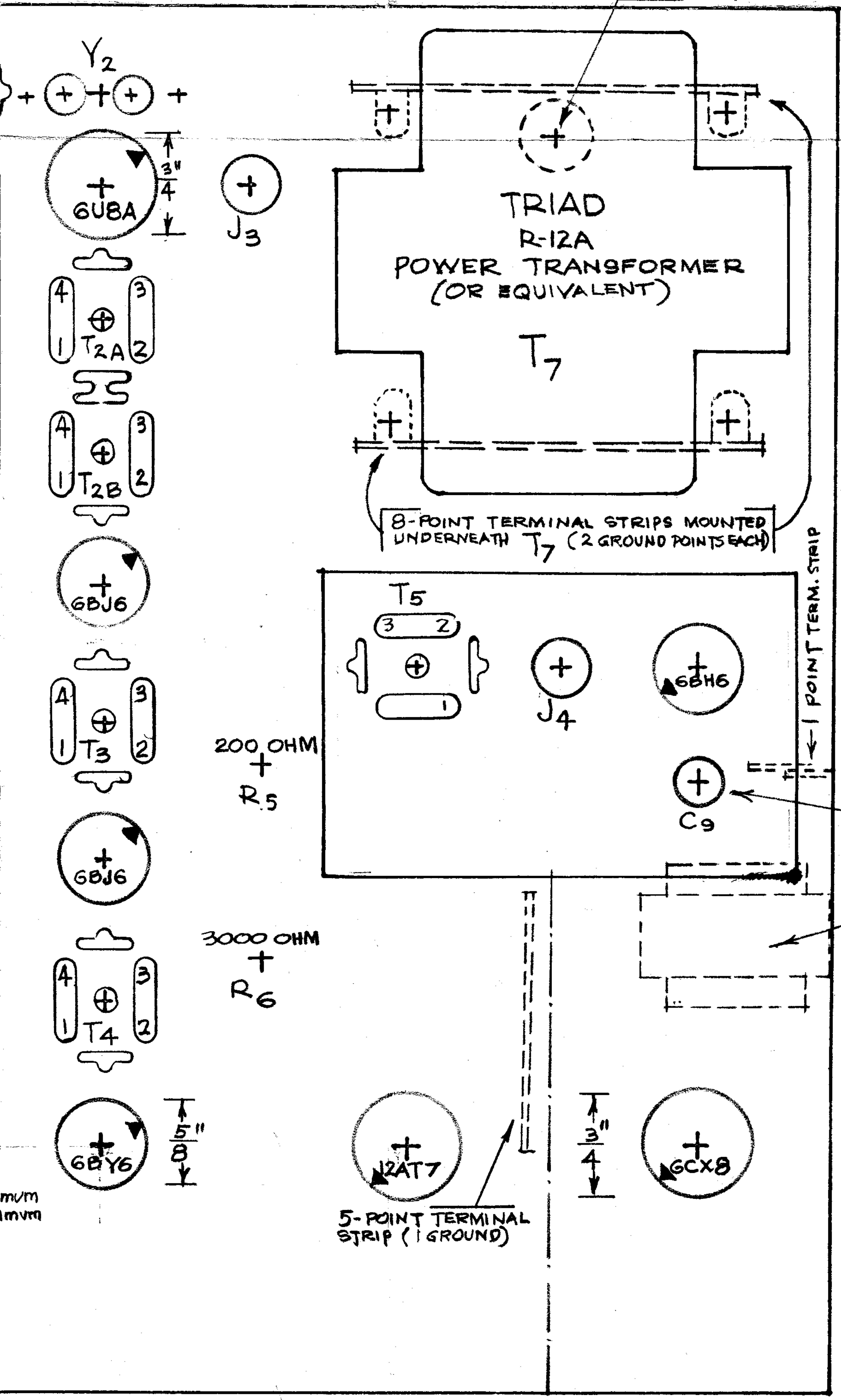

IF I.F. TRANSFORMER BASE PLATES ARE USED, THOSE FOR T<sub>1A</sub>, T<sub>1B</sub>, T<sub>2A</sub> AND T<sub>2B</sub> MUST BE TRIMMED WITH HACKSAW AS SHOWN ABOVE - OTHERS, LEFT SIDE ONLY - MOUNT ON TOP

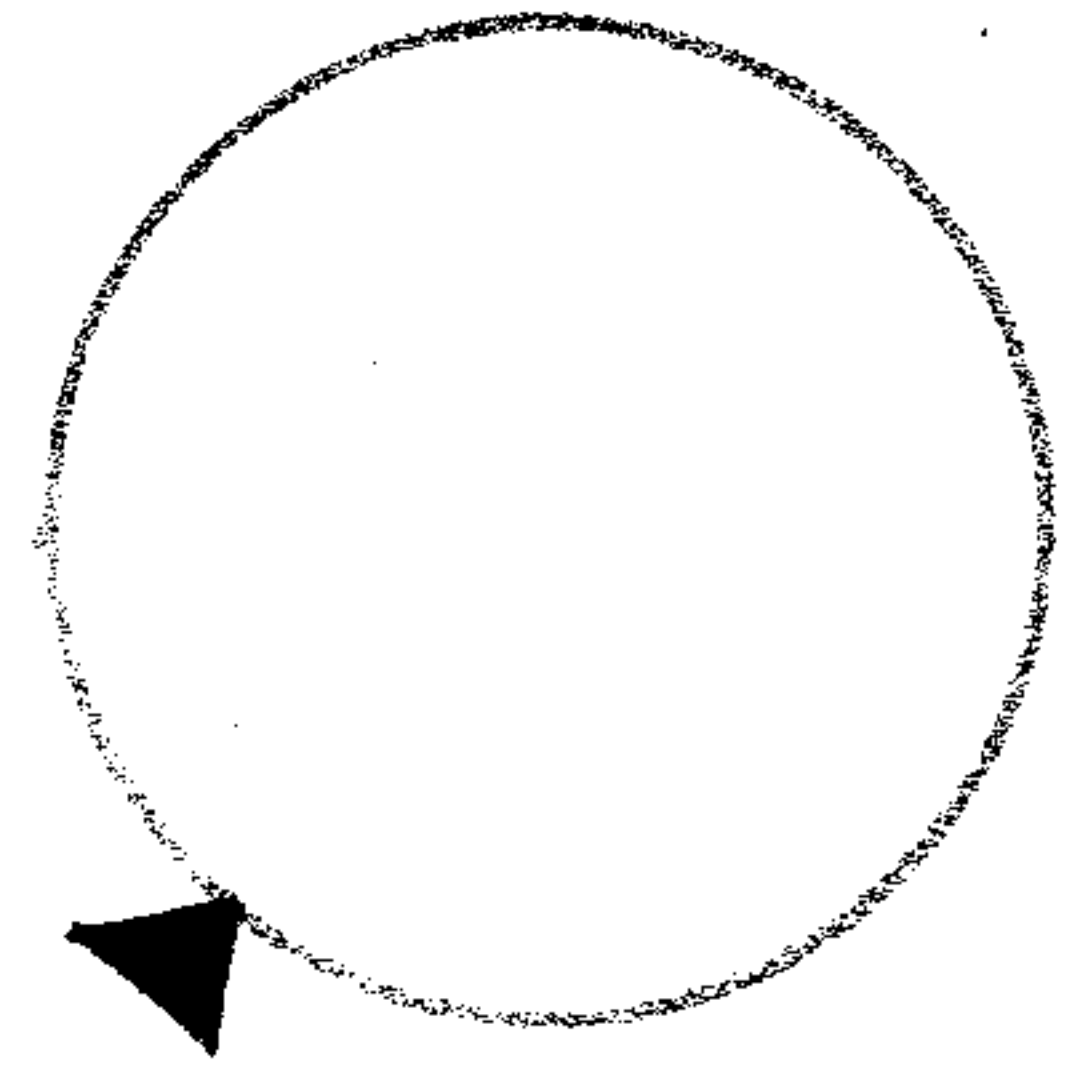

MAKE CERTAIN THAT ADJUSTMENT SHAFT OF ROTOR CLEARS HOLE

T<sub>6</sub> MOUNTED ON RIGHT SIDE OF CHASSIS

REAR SHAFT OF MILLER 2102 HACK-SAWED OFF FLUSH WITH REAR FRAME NUTS. BE CERTAIN YOU KNOW WHICH END IS REAR + WHICH FRONT!

THE MILLER 1461-BS IS MOUNTED ON 1/4 INCH 6/32 SCREWS USING THREE NUTS ON EACH SCREW - SEE BELOW

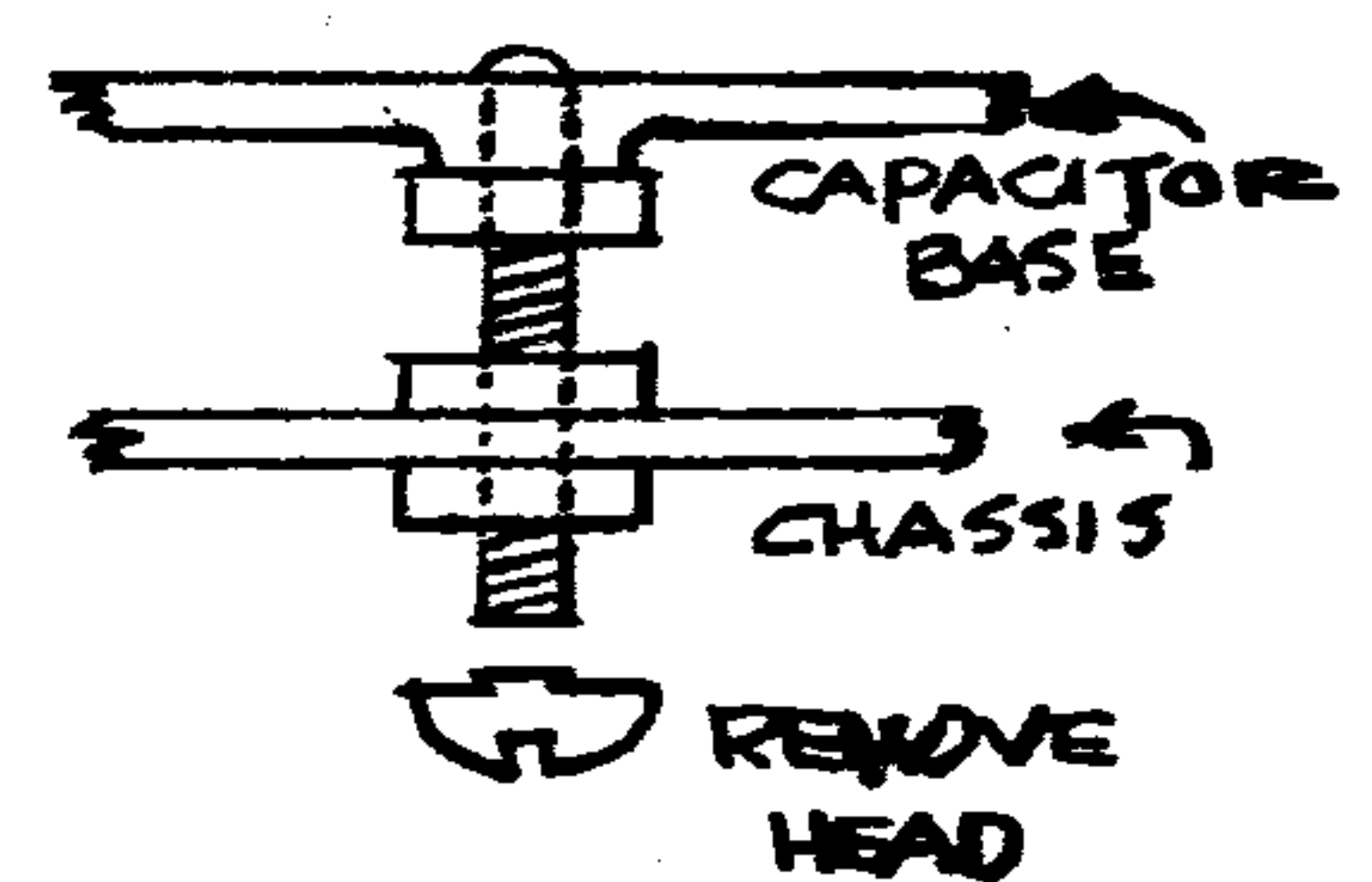

THE MILLER 2102 COMES WITH BRITISH SCREWS (THREADS) - MOUNTED SAME

CHASSIS

S4

S2

R4

C11

S6

S3

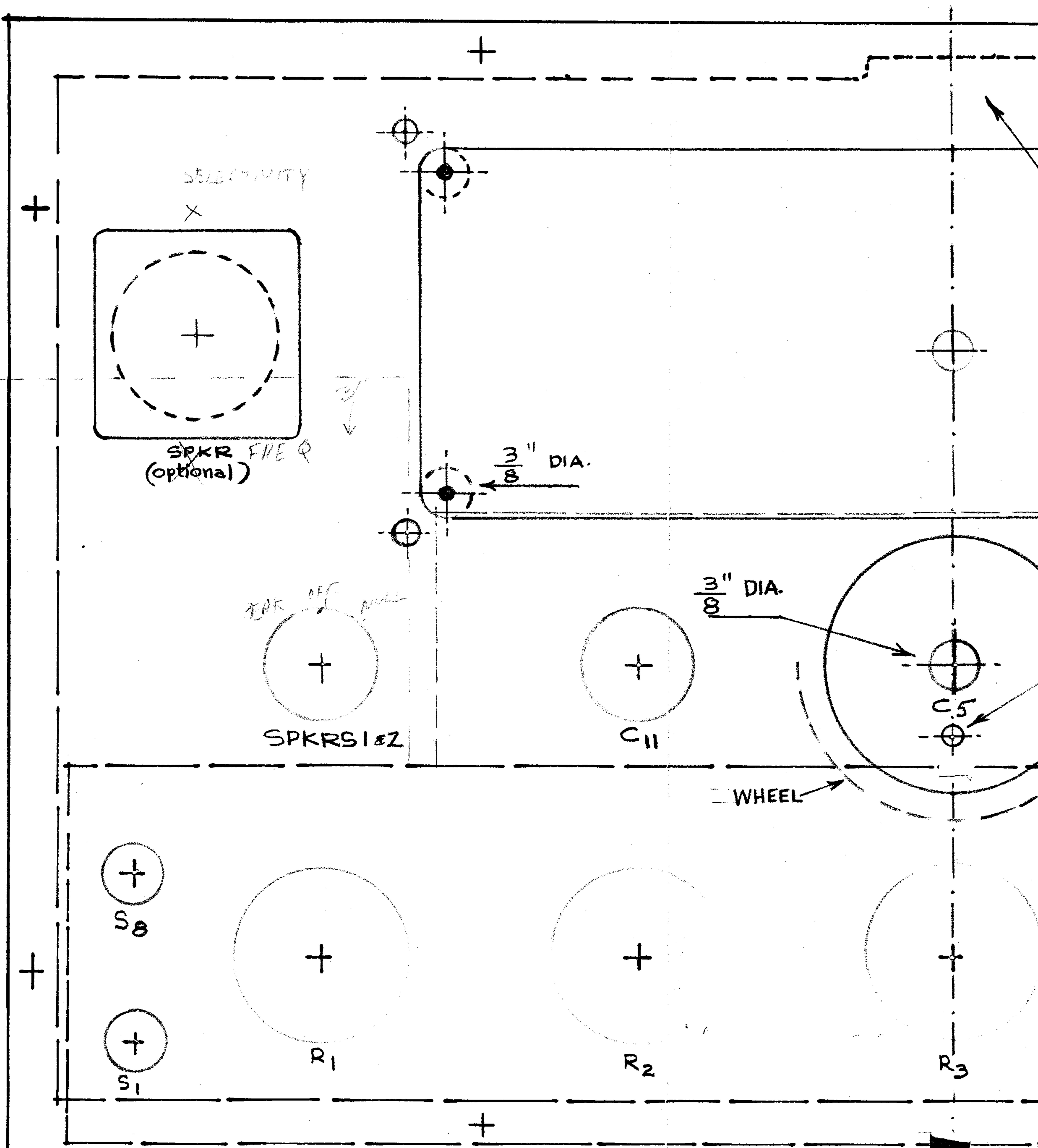

SELECTIVITY

X

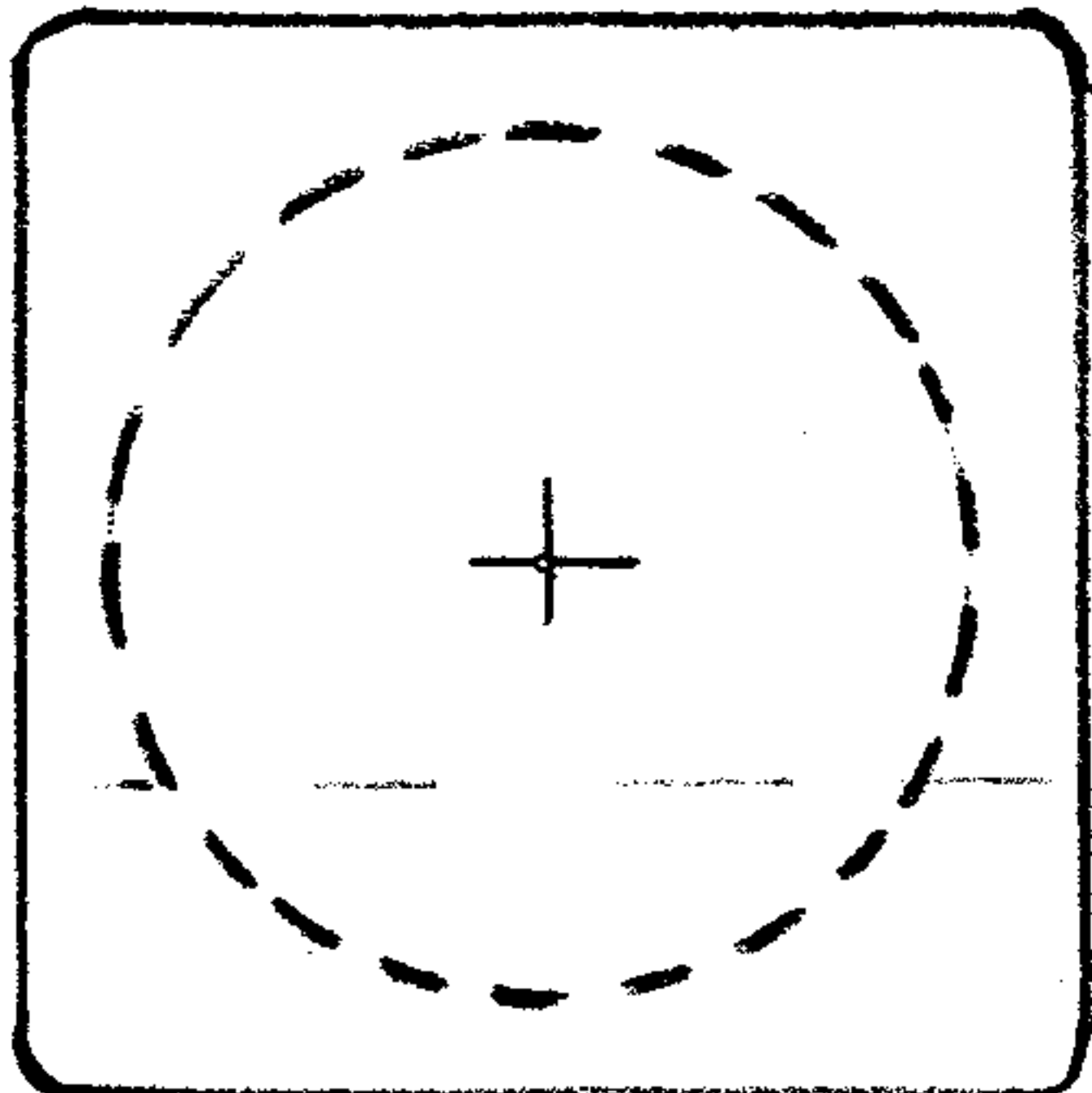

SPKR FIVE Ø  
(optional)

$\frac{3}{8}$ " DIA.

FOR OFF NULL

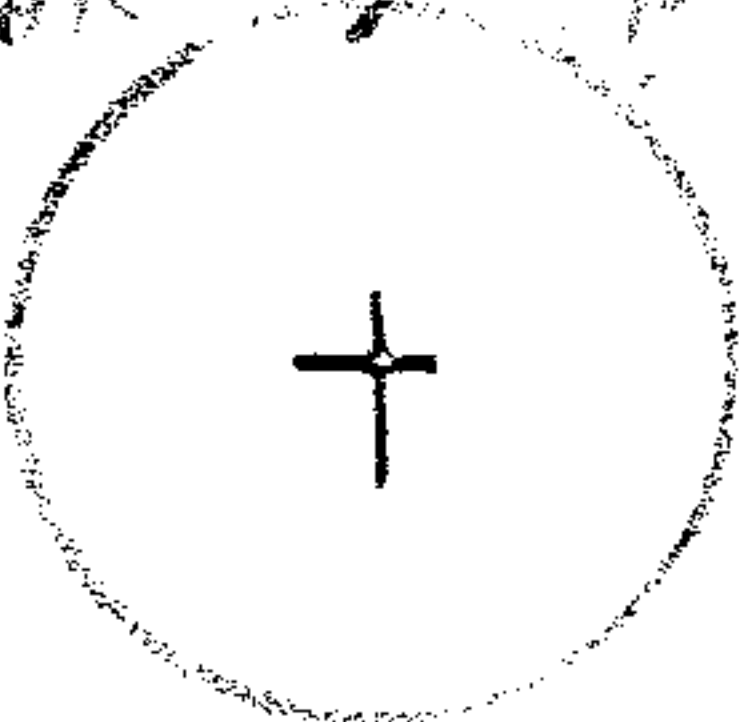

SPKR S1 & 2

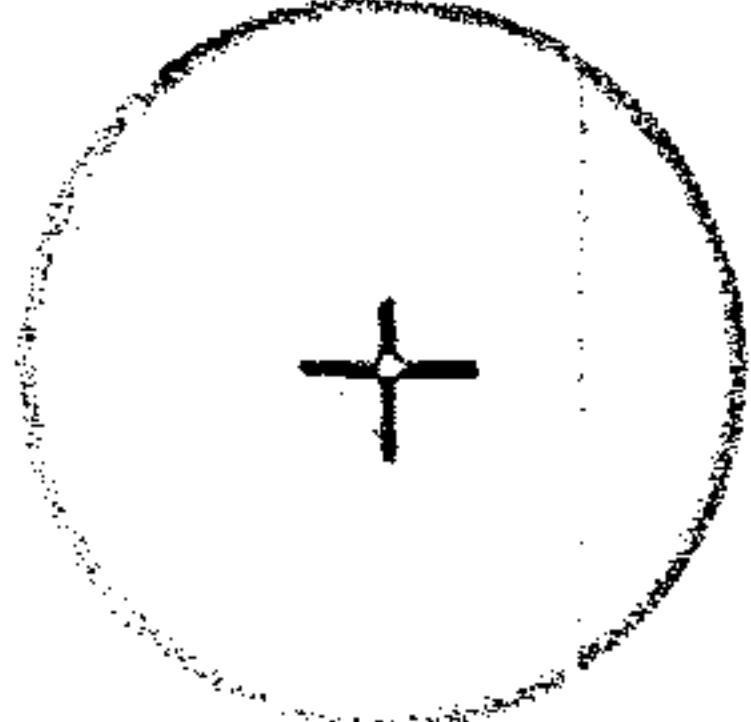

C11

$\frac{3}{8}$ " DIA.

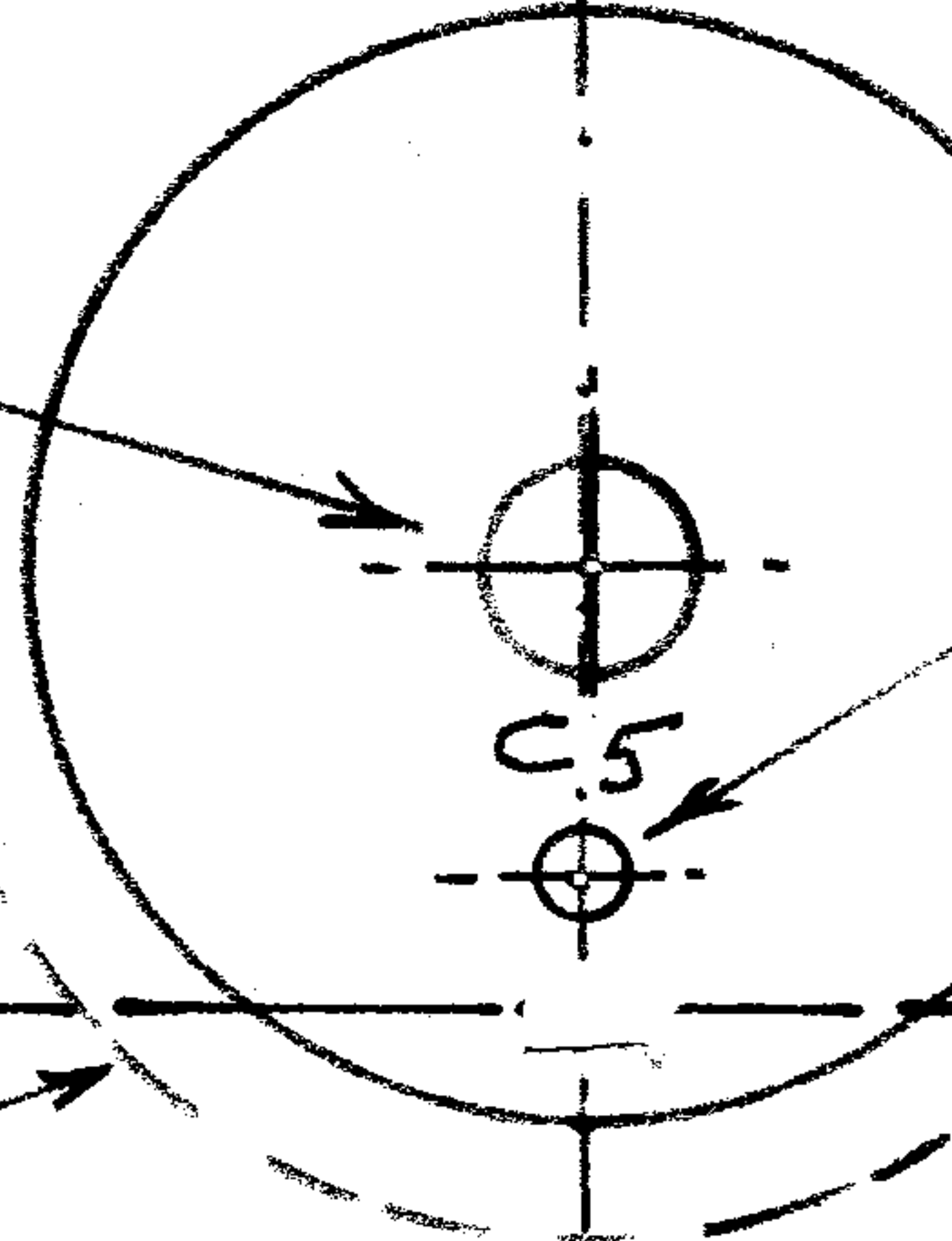

C5

WHEEL



S8

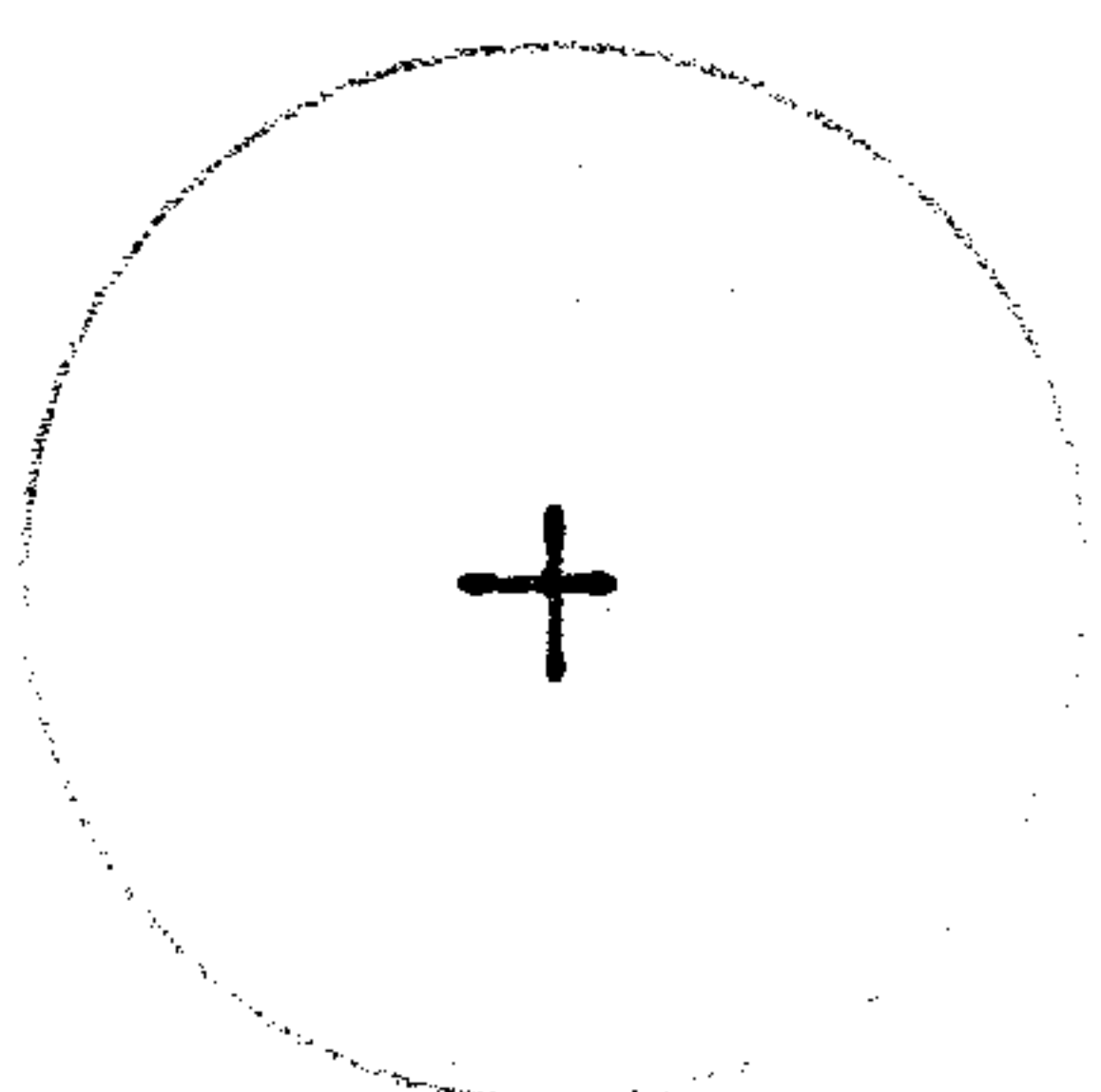

R1

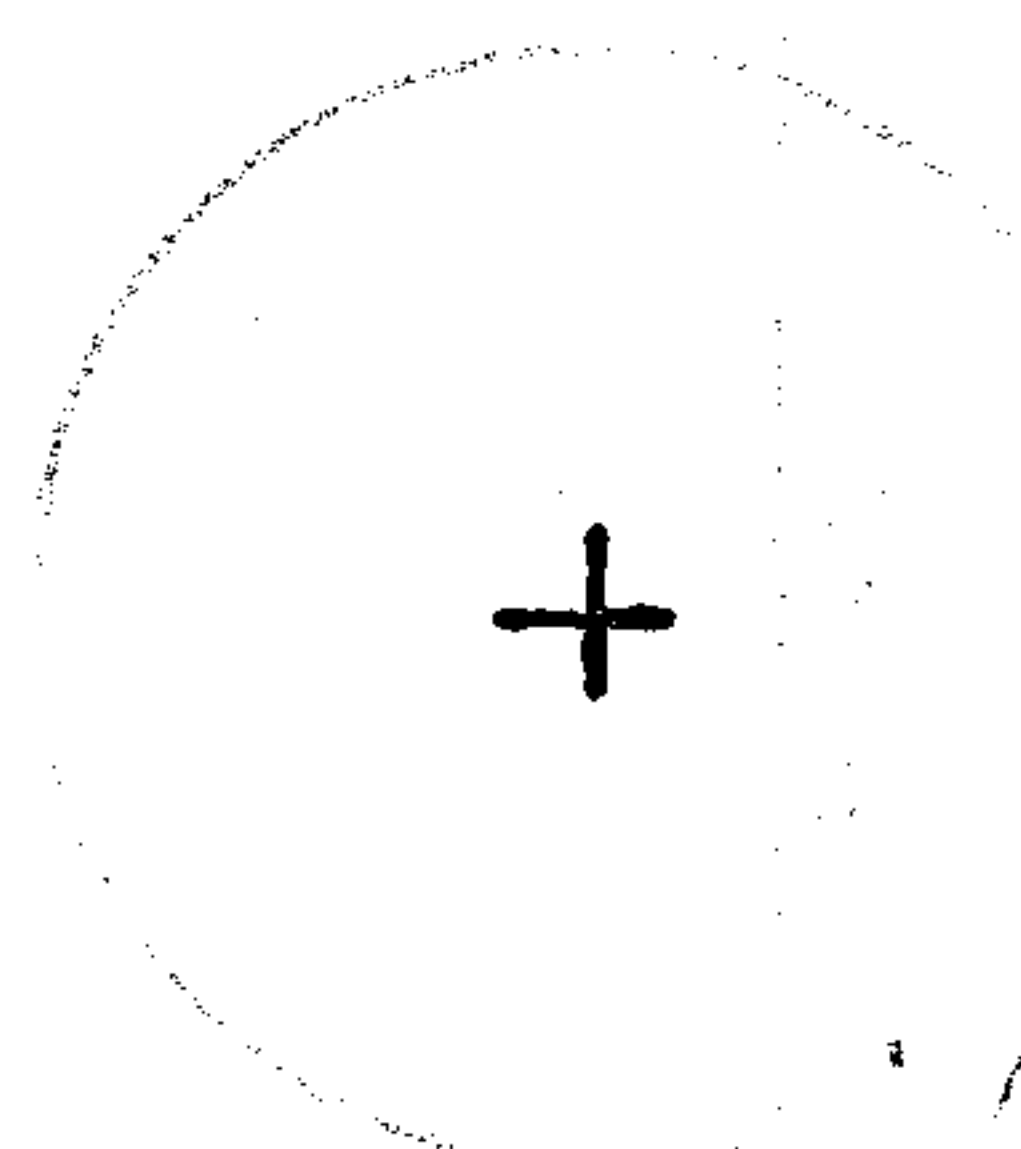

R2

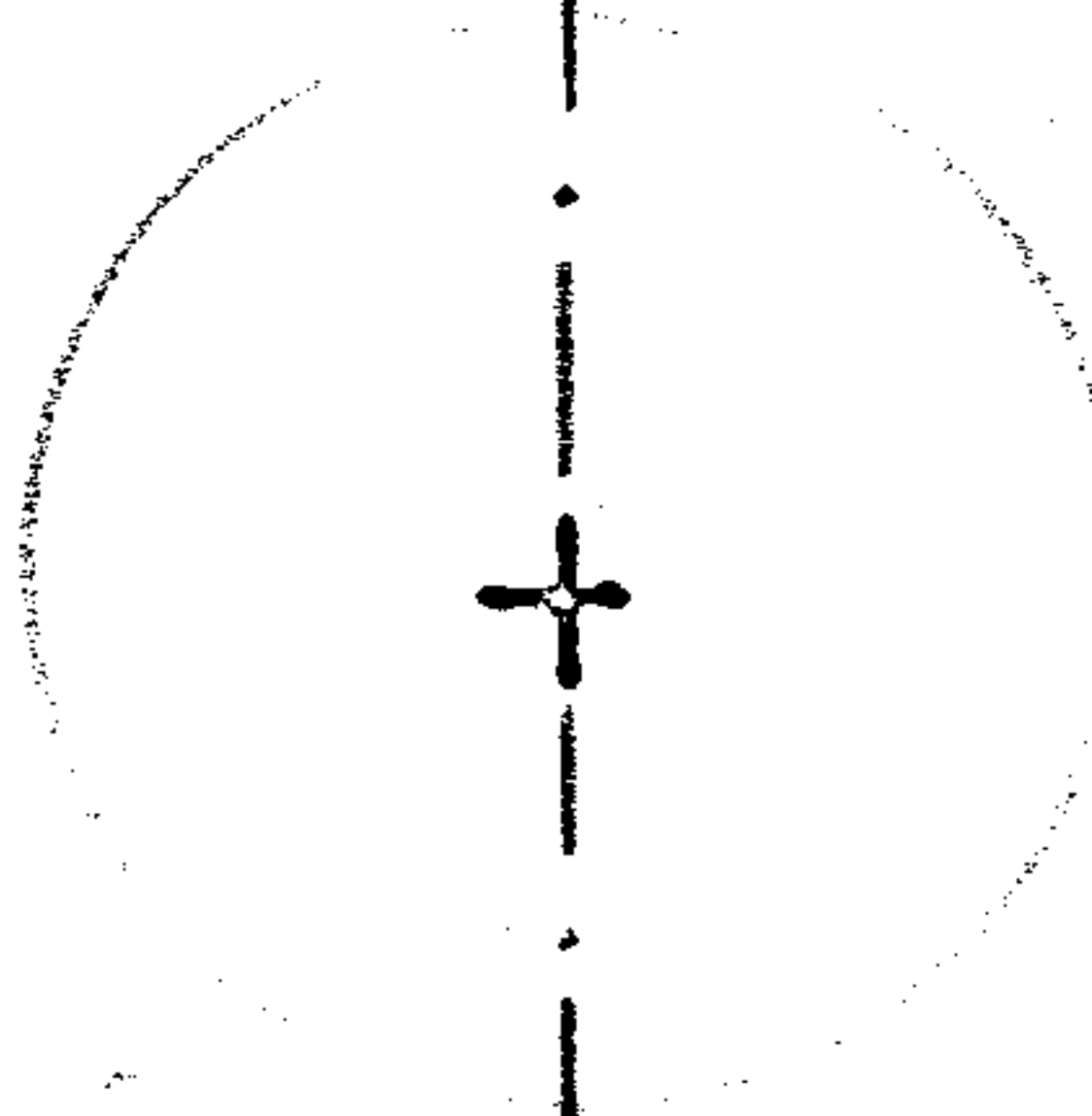

R3



S1

FRONT

NOTCH TO PASS DIAL  
POINTER-SLIDER IN  
AND OUT OF CABINET  
IF NEEDED.

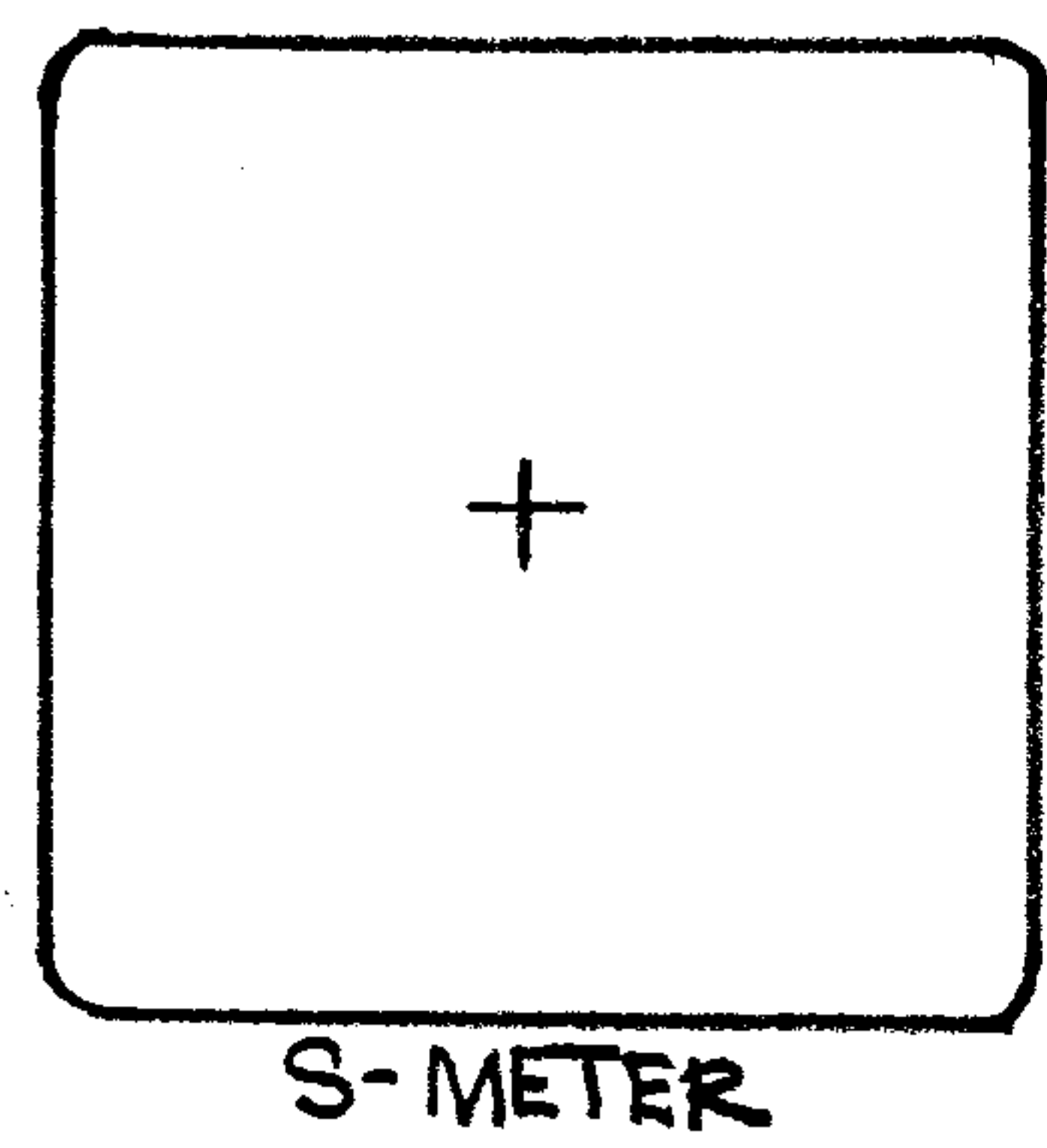

$\frac{5}{32}$ " DIA.

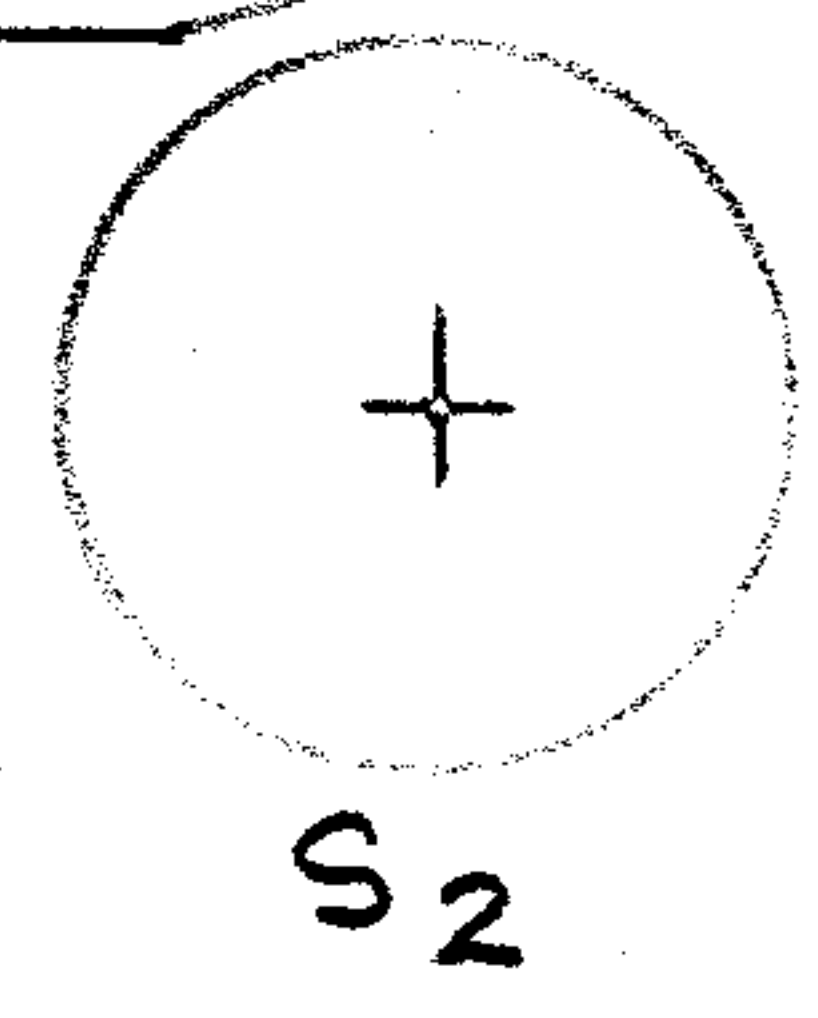

"A"

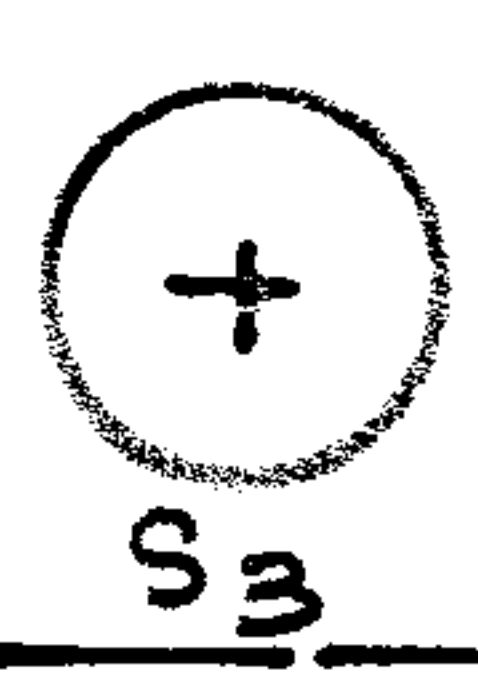
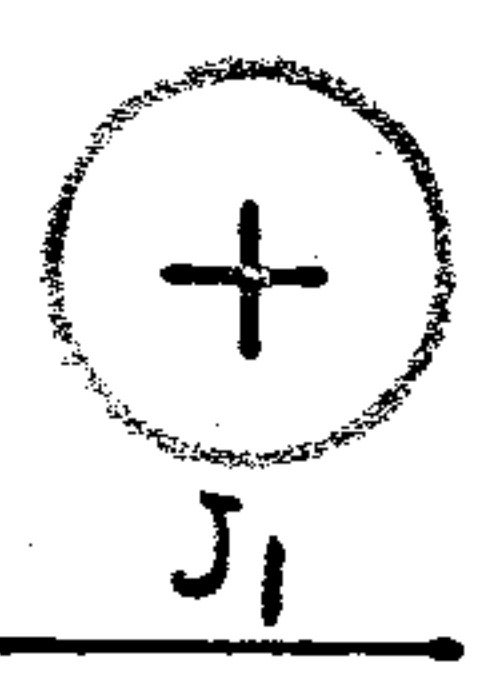
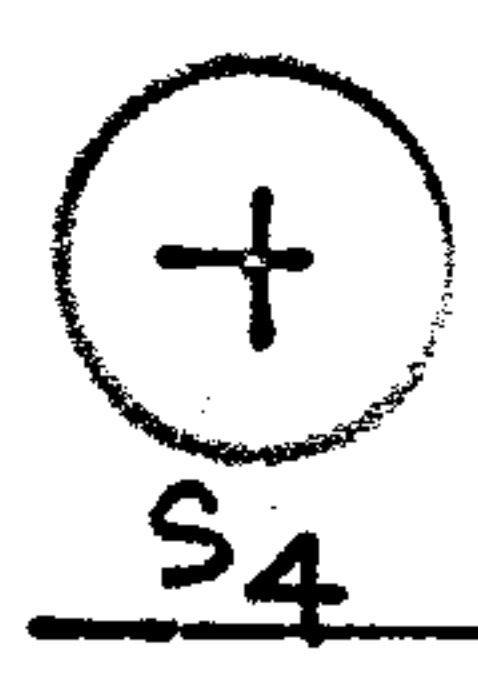
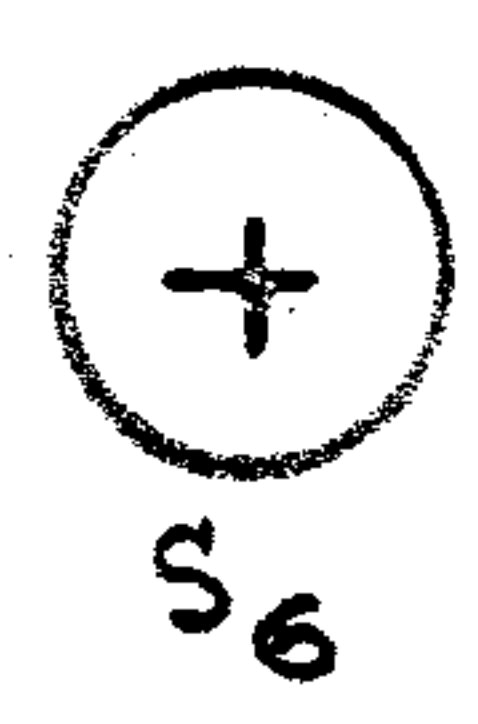
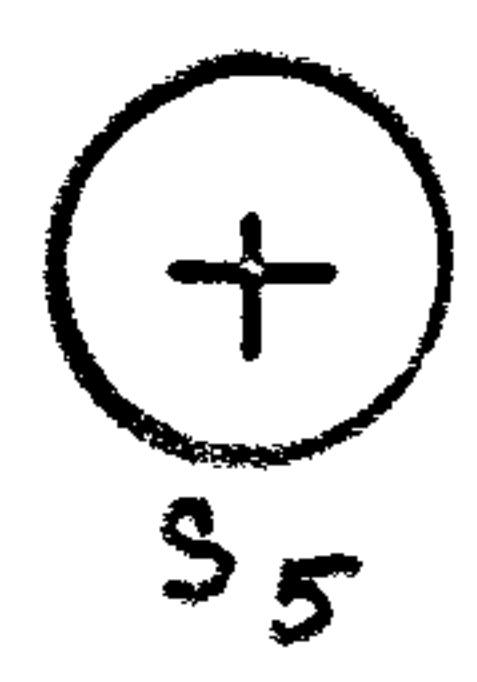
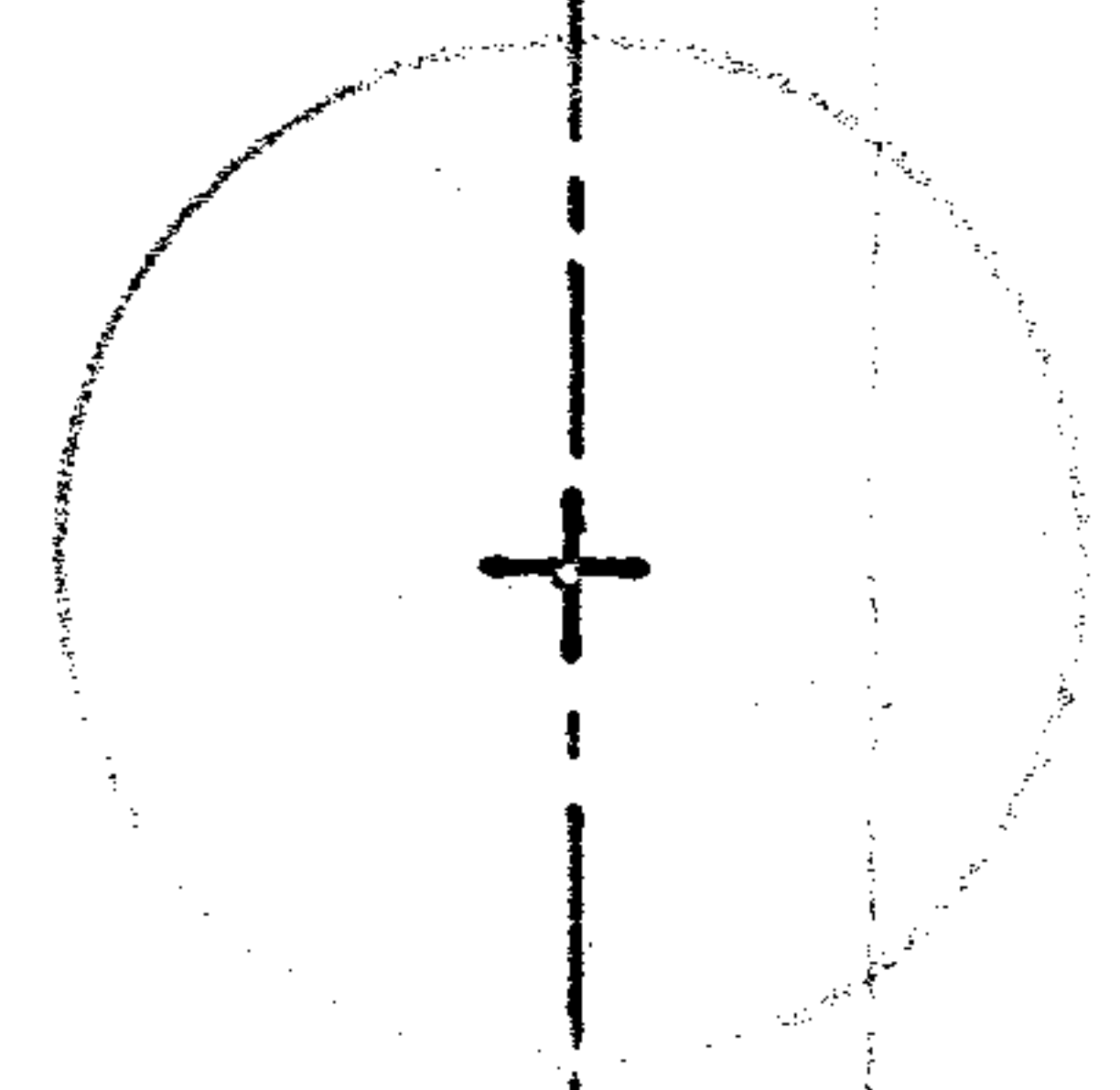
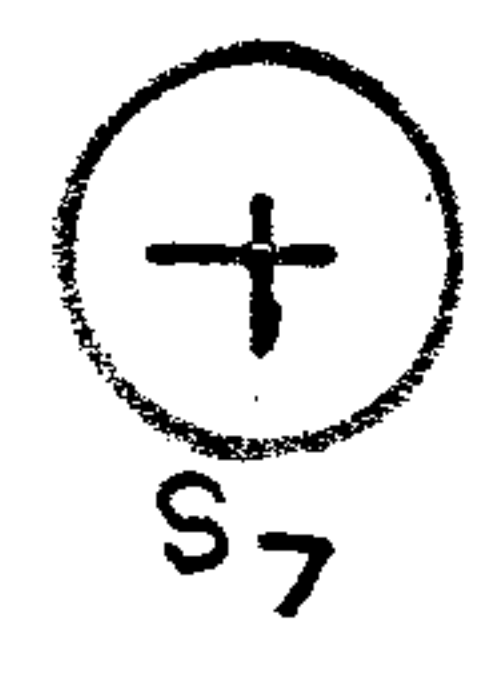
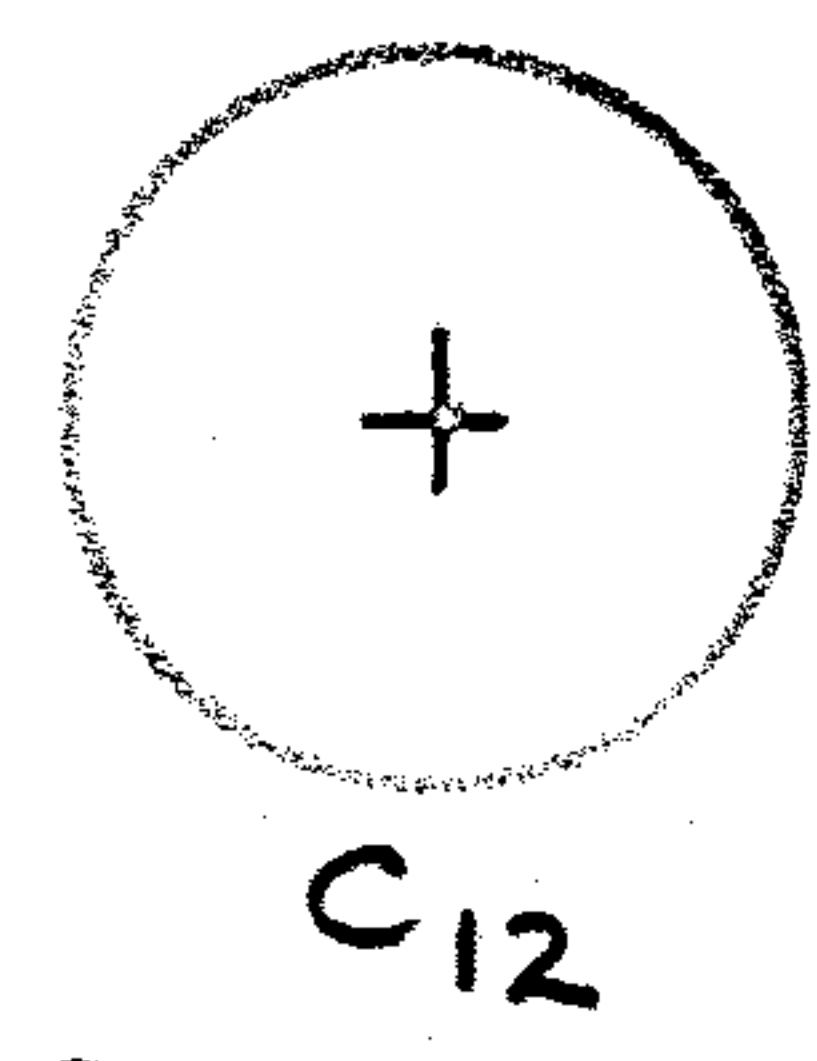

EL

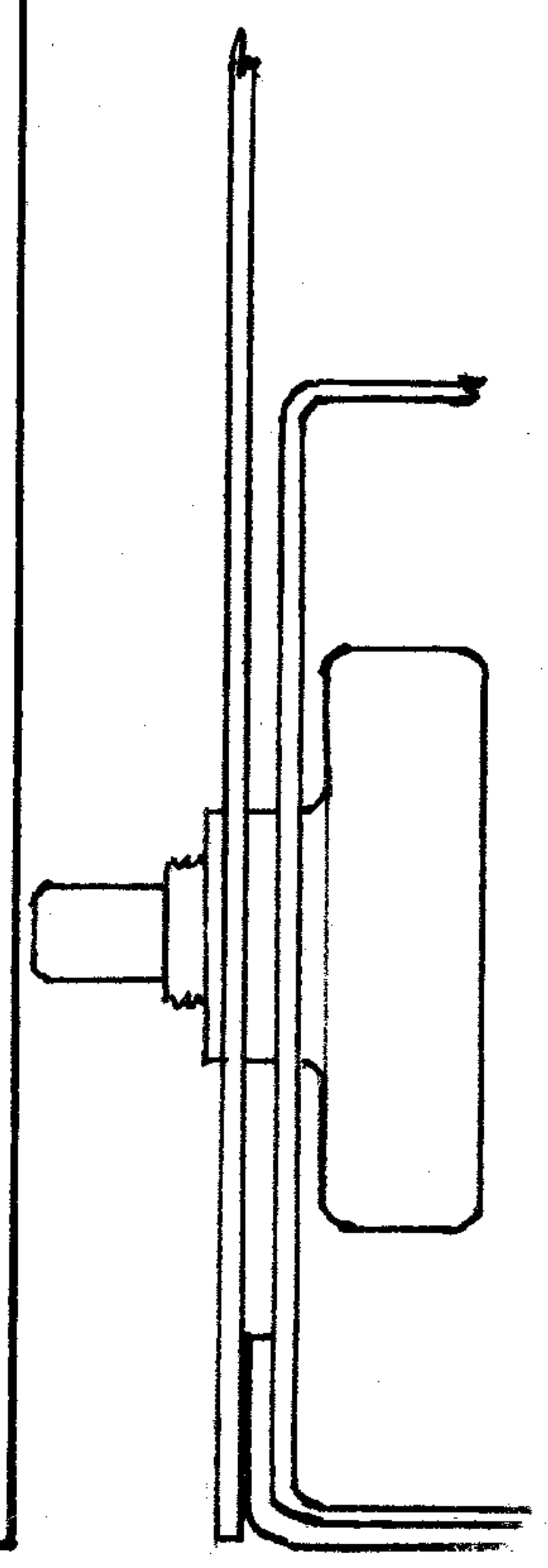

"A"-"A"



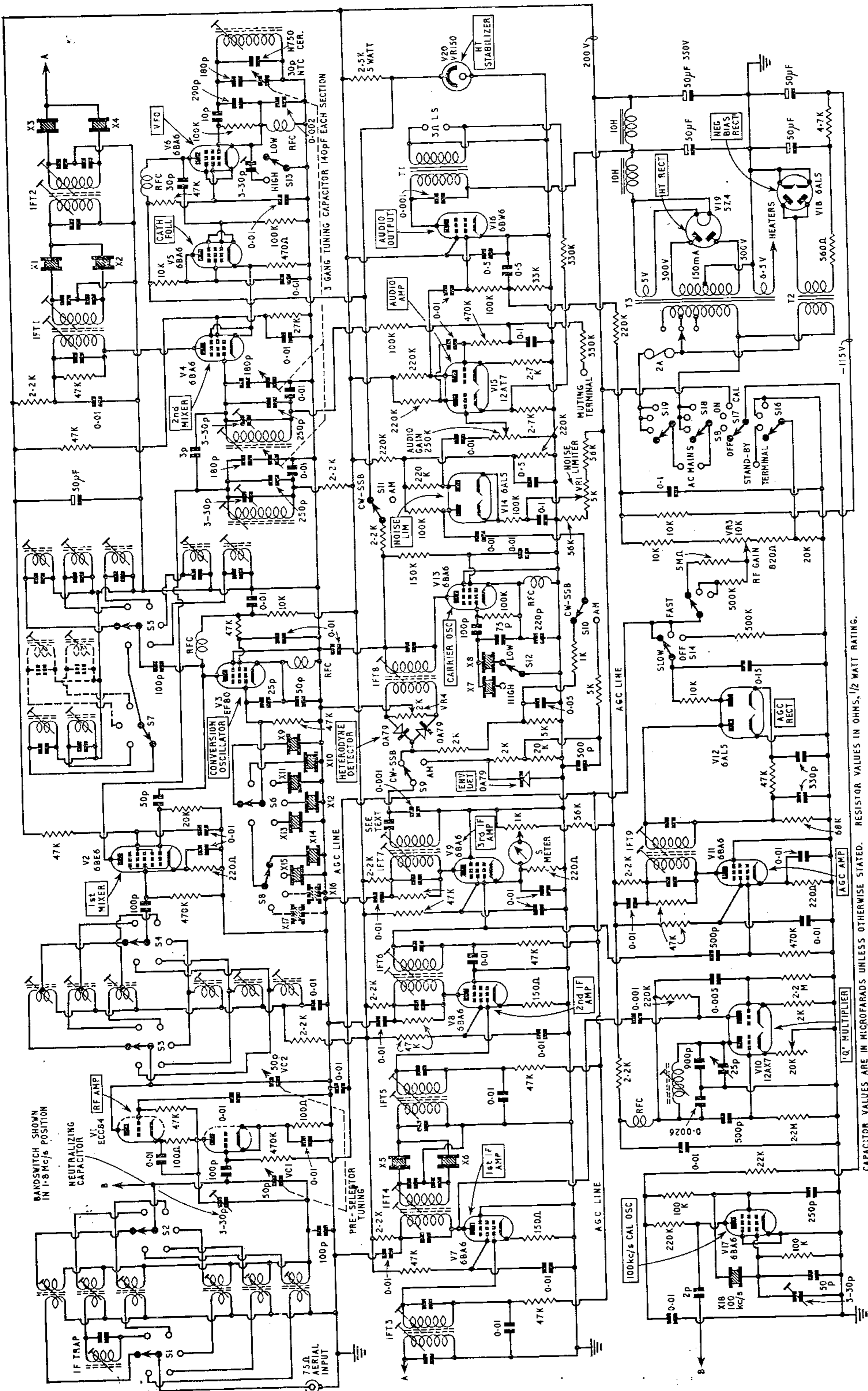

Fig. 4.93. Circuit diagram of the advanced double conversion amateur bands receiver with tunable first i.f.

- S1**, 2, 3, 5, 6, Yaxley type ceramic bandswitch, 6 bank 1 pole 6 way (shown fully anti-clockwise in the 1-5.2 Mc/s position).  
**S7**, 8, Yaxley ceramic bandswitch (10m band selector), 2 bank 1 pole 4 way.  
**S9**, 10, 11, Yaxley type paxolin (demodulator selector), 1 bank 3 pole 2 way.  
**S12**, 13, Yaxley type ceramic switch (sideband selector), 2 bank 1 pole 2 way.  
**S14**, S15, Yaxley type paxolin (a.g.c. switch), 1 bank 2 pole 3 way.  
**S16**, S17, Yaxley type paxolin, 1 bank 2 pole 4 way.  
**S18**, S19, Yaxley type paxolin, 1 bank 1 pole 4 way. (S16, S17, S18 and S19 are the operational switch).  
**X1**, X3, X5, X6, 461.9 kc/s (series resonant frequency).  
**X2**, X4, X6, 459.7 kc/s (series resonant frequency).  
**X7**, 459.3 kc/s (parallel resonant frequency in situ).  
**X8**, 462.3 kc/s (parallel resonant frequency in situ).  
**X9**, 7000 kc/s.  
**X10**, 9000 kc/s.  
**X11**, 6250 kc/s.  
**X12**, 6500 kc/s.  
**X13**, 6625 kc/s.  
**X14**, 8375 kc/s.  
**X15**, 8500 kc/s.  
**RFC**, all 2.5mH  
**T1**, audio output transformer with 200-250V primary, 13V winding connected across 6.3V line.  
**T2**, 13V winding connected across 6.3V line.  
**T3**, 300-0-300V 150mA, 5V 2A, 6.3V 5A.  
**T2m** 13V winding connected across 6.3V line.  
 All 0.01  $\mu$ F bypass capacitors are 400V d.c. working.

RESISTOR VALUES IN OHMS, 1/2 WATT RATING. CAPACITOR VALUES ARE IN MICROFARADS UNLESS OTHERWISE STATED.



## HBR-13C NOTES

(Assembled primarily for the HBR-13C builder but in many ways useful to anyone building the HBR-13 in other arrangements)

### General Comments

The HBR-13 is a double-conversion superhet covering primarily the ham bands only, using plug-in coils in the front end, 1800 kc. transformers padded down to 1610 kc. in the first i.f., and very effective 100 kc., iron-core transformers in the second i.f. amplifier. With the exception of the plug-in coils, standard parts are used throughout. The receiver is exceptionally stable and has a very high signal-to-noise ratio. The overall-passband of about 3 kc. 40 or more db down provides true "single-signal" selectivity (1) on c. w. and yet is not so sharp that it impairs intelligibility on SSB phone. The circuitry used is straightforward and to the point, incorporating those things needed to provide the sort of results desired, but not including additional gadgets that could only confuse the issue.

Separate gain controls are provided for the r. f. stage, the second mixer, and the two i.f. amplifiers. This may seem like an unnecessary complication, but it is one of the features of the receiver. Normally the r.f. stage is run wide open, the mixer gain at about halfway, and the i.f. gain is advanced only enough to provide suitable signals at the detector. The r.f.-stage gain is backed off only when a very strong signal attempts to take over the receiver. The plug-in-coil type of front-end greatly simplifies the receiver's construction, and the band-set and band-spread methods used eliminate the usual "tracking problems". When properly done, this type of front-end also does away with the long leads, multiple switching contacts, and poor L-to-C ratios usually present in the conventional band-switching type of front-end, with the to be expected improvement in performance. Plugging in coils isn't as convenient as switching, but the improved sensitivity and gain are readily apparent, especially on the 10-, 15- and 20-meter bands.

The 3500-kc. crystal oscillator provides a convenient frequency standard, always available at the flick of a switch. The fundamental and harmonic frequencies of this oscillator furnish signals at the low edges of all the bands covered by the HBR-13. It is rather convenient to have always available a reliable indication of the lower band-edge frequency in these days of DX chasing via the v.f.o. method. Furthermore, this oscillator provides a signal of rock-bound stability at an amplitude just right for a touch-up tuning of the receiver's over-all alignment if and whenever desired. Having aligned it originally, the builder most certainly is qualified to maintain the alignment precisely "on the nose".

(1) "Single-signal selectivity" means the elimination of the audio image in code reception. In other words, you tune into a signal, go down to zero beat and find no beat note on the other side. This should not be confused with "super-selective c.w. reception" which requires an i.f. amplifier so sharp that it will accommodate a single c.w. signal with very little to spare. This latter type of i.f. amplifier is too sharp for phone reception.

The 6 db "NOSE" of the HBR-13 is such that the average S7 code signal can be "nosed in" as solid copy to the experienced ear, even though a similar signal is present only 250 cycles or so away. Furthermore, these average signals will be "single-signal" to the extent of appearing only on one side of zero beat. Very strong signals will show a weak audio-image on the opposite side but will be attenuated to where a relatively weak signal can be copied over them with no difficulty. An initial exposure to this sort of selectivity can be an enlightening experience. The inherent selectivity, stability and adequate b.f.o. injection of the HBR-13 make it an outstanding performer on SSB.

The receiver alignment is rather easily accomplished by use of the transmitter exciter as a signal generator and the receiver S meter as the indicating device. At full retail net, the HBR-13C costs under \$170.00 to build, complete with tubes, crystals and cabinet. Bargain hunters and owners of well-stocked junk boxes can do it for considerably less. If the project appeals to you otherwise, don't let the rather formidable looking schematic frighten you away. Broken down into its various sections, it's nothing more than a comfortable group of well-known circuits, completely familiar to most of you.

While the HBR employs the simplest of circuitry -- and should be relatively easy to copy -- it is no undertaking for the fellow who has little or no previous building experience. If you are inexperienced, BEFORE YOU EVER START, may I suggest you contact an EXPERIENCED ham friend who will be willing to help you if you run into difficulties. In other words, if you can't even make a decent solder joint -- forget about this project! -- and save your money.

Ted Crosby has taken the time to go over, and in many cases, rewrite for me, all the material that is contained in these notes. In this way you can be sure that any information I am passing on to you meets with Ted's approval, 100%.

Ted Crosby's address is 28901 Crosby Drive, Sun City, California 92381. Ted has always been kind enough to try to answer any problems encountered by HBR builders. Be thoughtful enough to include a self-addressed, stamped envelope for your answer.

-----

### Major mechanical considerations

The HBR-13C main chassis is aluminum 10 x 14 x 3 inches. In the interest of taking that "last little step" towards having the most stable receiver possible, use a well-made chassis. Buy one which has those triangular strengthening gussets of metal welded in at each corner. (Premier brand, available from Lafayette.) Three  $\frac{1}{2}$  inch holes are punched along the upper edge of the right side of the chassis for ventilation, and another series of  $\frac{1}{8}$  inch holes are drilled across the left top edge of the 2 x 5 x 7 chassis for the same purpose. Holes in the cabinet rear wall for the antenna connections, speaker plug, accessory socket plug, and fuse holder may be made with a 1-inch socket punch and nibbler tool or a section 2" x 14" above bottom of cabinet may be removed. The  $\frac{1}{16}$  inch steel panel may seem rather too thin at first glance. However, once the receiver is completed and cabinet installed, the additional front-panel screws used, plus the cabinet's rigidity, provide good over-all mechanical stability. The cabinet has 35 one-half inch holes punched in its bottom -- arranged to give equal ventilation over entire area, but place this pattern two inches from sides and back and one inch from front. Rubber feet at each corner are necessary to permit air to enter underneath receiver.

-----

In mounting the BFO, fasten the U-shaped portion of the BFO enclosure to the chassis and mount all the components on the two horizontal sides of the other portion of the box. Be sure to locate the tube and the BFO coil so as to provide sufficient mounting space for C-9 and C-12.

The BFO assembly is completely enclosed in a 1 5/8 x 2 5/8 x 3 3/8 inch aluminum chassis box, the external connections being made with shielded wire. The various parts and connecting wires are mounted on the top or cover portion of the box. The bottom section is bolted to the main chassis, and a 1/4 inch hole drilled therein to provide an exit for the shielded wires. (Be sure to mark the three shielded wires in some way, so you know which is which when you go to wire them into place beneath the chassis!)

Before mounting the MAPC-35B used as a "pitch control" on the BFO unit, file or mark a notch on its shaft, in order that you may tell when it is set to a "half-capacitance value" after the BFO enclosure is closed up. So positioned at "half-capacitance", adjust the #1711 tuning-slug to the receiver's "passband center frequency". Then it is easily possible to move the BFO frequency in either direction (higher or lower) for the reception of upper or lower sideband. It is very important that the pitch control be properly set (approximate 500-800 cycles above or below the center of the passband frequency) so that the SSB signal does appear at the proper point in the passband of the receiver. Severe clipping will result when the pitch control is too far removed from "center passband frequency". Do your SSB tuning with the dial, not the pitch control.

- - - - -

<sup>If</sup>  
In your Miller 1461-BS 3-gang tuner comes with padders, unscrew the adjusting screws and discard it as well as the top or variable plates of the padders. The bottom plates may be left attached to the gang condenser frame, but otherwise ignored and unused.

- - - - -

Ceramic tube sockets are preferred for the front end tubes (r.f. amplifier, mixer, first oscillator). You must use one at least for the first oscillator tube. Bakelite or mica-filled sockets may be used on the balance of the receiver.

- - - - -

Use ceramic sockets for your front-end coil sockets, at least for L-3. This will insure proper anchoring of the coil form pins. If you have a frequency shift when your receiver is jarred, this might be due to a slight movement of the L-3 coil in its socket. If your coils are not held tightly enough, hold your soldering iron onto the tip ends of two or three of the coil form pins long enough to soften the plastic form slightly. Push "outwards" on the pins very gently just enough to move the two or three pins slightly away from a true even-spaced position. There should be enough mis-match of the form to the socket that a little force is needed to seat the coil. The coil will sit as solid as a rock -- and be as stable.

- - - - -

Watch the placement of shields around the plug-in coils and the tuning gang. No shield should be closer than one-half inch from any coil to avoid lowering the "Q" of the coil, and distances closer than this to the tuning capacitor will increase the minimum capacitance of the unit, and you might have troubles "covering the band".

- - - - -

Most HBR-13C builders will prefer the four i.f. transformers in the second i.f. strip, with the "input-stage" "back-to-back". However, inevitably some will want to consider five or six transformers and there is no law against such plans. However, it is obvious that a different layout of parts will be required for this sort of modification. You will need to extend the detector end of the string towards the right-hand side of chassis. In this and any other major modification, the builder is strictly "on his own" insofar as drawn-to-scale panel/chassis templates are concerned.

- - - - -

The dashed lines which outline the 1610 kc and 100 kc i.f. coils in the QST HBR-8/11/13 schematics are there for one purpose only, "to outline the coils". The dashed lines do not indicate shielding, as some may be lead to believe.

- - - - -

*two side front flanges*  
The ~~front flanges~~ of the Wyco cabinets must be reduced to accommodate the width of the chassis. This reduction is best accomplished with a "nibbler" tool and for the HBR-13C, approximately 1/4th inch was removed all around. This leaves the holes for screws used in mounting panel to cabinet just about centered in the remaining flange.

*no need for notch in top front flange - dial has been lowered to take care of this*

#### A few electrical hints

The 10 ohm fixed resistor in the 6.3 v. leads to the S-meter panel-lighting bulbs drops the applied voltage sufficiently there will be no pre-mature burn-outs.

- - - - -

The R-12A power transformer used in the HBR-13C is slightly larger physically than the R-10A used in the HBR-8/11/12, and carries slightly higher voltage and current ratings. Yet, due to its popularity and greater sales, it costs less than the R-10A. For those using the recommended sil. diode rectifiers, the Stancor #PC-8420 power transformer is a completely satisfactory substitute for the R-10A and R-12A (no 5 v. winding for rectifier tube) and is available at a substantial saving. (See Lafayette or Allied catalogs.) Due to the lack of sufficient chassis space, the smaller R-10A or Stancor PC-8420 must be used with the smaller HBR-8/11 cabinet and chassis.

- - - - -

The recommended "shield hookup and grid wire" for all of the HBR-13C shielded leads is made by Belden. It is relatively small and flexible, yet the inner lead is heavy enough to carry the heavy filament current. Used between power transformer sil. diodes and filter chokes -- clamped under flanges at chassis bottom. The Belden "shielded grid wire" available from Allied Radio -- 1965 catalog, item #47T780 for a 25 foot spool. Actually, this shielded wire is ineffective at 120 cycles (the full wave rectified 60 cycle AC pulsating current) but is the most effective procedure from a mechanical standpoint never-the-less.

- - - - -

Other shielded-wire connections are the three wires from the BFO enclosure, the lead between the antenna input terminal and pin #1 of the L-1 socket, and the leads to L-4, from CR2 and CR4.

- - - - -

Pre-calculating the physical placement of many of your long and non-critical leads is important in order that they can be snugly tucked away out of sight. Do this prior to the installation of the critical portions of the receiver's wiring. Place ground lugs at all convenient locations -- (socket and parts mounting screws, etc.) prior to attempting the wiring job proper.

- - - - -

As you may have suspected, sticking 12 tubes plus the necessary accompaniment of parts into such a relatively small space does present some problems. However, if a little forethought is given to the wiring job, no particular difficulties should be encountered. Just be certain you do not get ahead of yourself to the point of leaving out a connection you will later find you cannot make because it is covered up by some other equally important connection or component. You will have room for everything provided you make good use of the available "vertical" space. Resistors and capacitors, for the most part, should be mounted in a vertical position. Obviously, a small-tipped soldering-iron is a must. Do not use the two ends of the chassis for parts-mounting purposes, except as indicated on template. To do so would interfere with inserting and removing the chassis from the cabinet.

- - - - -

The "wee" speaker on the HBR-13C shown with the October 1965 "QST" article is a Lafayette item -- #99 R 6122 -- a Jap speaker for autos. It is purely an auxiliary item, but performs quite well for CW. Too limited in low-frequency response to cause any microphonics. To match the S-meter, a piece of  $\frac{1}{4}$  inch Plexiglass was mounted over the speaker's panel opening. The speaker itself is completely enclosed and two small right-angle brackets were made of aluminum to mount the "box" top and bottom.

*not as efficient (less volume) as the recommended external speaker discussed in next paragraph.*

On the subject of speakers, a 5 or 6 inch speaker is to be preferred. The larger sizes tend to "bassiness" when used with the HBR. Buy a good quality speaker with the heaviest possible field magnet (say around three ounces) and mount it in an open-backed 10 or 12" square enclosure. Do not cancel out the "open-backed" requirement by hanging the unit against the wall of the operating room. In passing, a good speaker costs closer to \$5, than to \$2.

- - - - -

Be sure you are using high impedance headsets, 20,000 ohms or more preferred. Poor speaker volume (if headset volume is satisfactory) may be due to a mismatched speaker and output transformer, or a speaker or output transformer of poor quality.

-----

Use #18 (or heavier) SOLID plastic coated hookup wire. Make all connections in the front end, i.f. strips and detector areas, as short and direct as possible. Helps to eliminate stray capacitances. Be sure the first-oscillator/mixer circuit is as secure and rigid mechanically as you can possibly make it. This will avoid mechanical frequency instability every time you jar the receiver appreciably. Keep filament and B+ leads down against the chassis.

-----

Avoid overloading the filament leads to the tubes. Break the filament leads from the transformer into 2 or 3 "branches" and have each "branch" serve only 4 or 5 tubes.

-----

Anticipate probable sources of trouble as you build.

1. Check all bypass capacitors for shorts before installation.
2. Check all resistors for proper ohmage before using.
3. Check resistance of the windings of the Miller i.f. transformers before installation. Even a manufacturer like Miller can come up with an occassional resin joint on the tiny wires used in these coils. All 100 kc. coils should show the same resistance.
4. Even though they are brand new, pre-check your tubes, in an accurate tube-checker.
5. Check all switches for absolute "make and break" contact before installing.

-----

Some electronic comments.

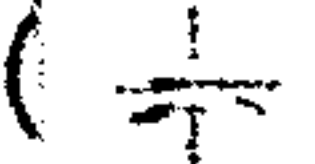
On a schematic, a variable capacitor is represented by a straight and curved line, (  ); the straight line representing the stator, while the curved line represents the rotor-or moving plates of the capacitor. In every instance, the stators are drawn to indicate a connection to a "hot" point in that particular circuit (going either to plate or grid circuitry) while the rotors always go to the "cold" or ground side of its particular circuit. Be sure you connect them that way! Otherwise, hand-capacity tuning effects will be the result.

-----



While on this subject, let me point out that the QST schematic is correct insofar as the various connections from the plug-in coils are concerned. In other words, the "cold ends" of the primaries and secondaries are to be wired up exactly as drawn. A reversed connection at any point can, and will, make a difference in the receiver performance. A reversed tickler, or secondary coil, to the first oscillator will prevent 1st osc. functioning, and will kill the entire receiver. Instability, loss of gain, and unwanted oscillations will be the results of reversed connection at the remaining points.

- - - - -

As specified in the parts list furnished with each HBR-13C schematic, the RFC<sub>1</sub> and RFC<sub>2</sub> home made chokes are an absolute "must" when the JWM-2102 capacitor is used. If you do not have the "parts list" the specifications are repeated here:

RFC<sub>1</sub> -- 22 turns of enamel wire, closewound to an inside diameter of 1/8 inch. Self-supporting and mounted horizontally, immediately adjacent to pin #5 of the L<sub>2</sub> coil socket. (Serves to lower the frequency of the possible resonant<sup>2</sup> UHF circuit in the plate of the tube which sometimes could cause parasitic oscillations.)

RFC<sub>2</sub> -- to be installed vertically and immediately adjacent to pin #2 of the 6AZ8 RF pentode tube-socket, with .02 bypass capacitor connected to the B+ end. (Re-read that last line -- important.) Consists of 12 turns of #22 enamel wire, closewound to an inside diameter of 1/8 inch. Keep these two RFCs well apart.

NOTE: Should you by mistake connect the .02 bypass capacitor <sup>directly</sup> to pin #2, as is the normal procedure, the effective presence of RFC<sub>2</sub> will be cancelled out completely.

- - - - -

Tube shields are not required nor used in an HBR receiver, provided miniature sockets equipped with the one-half inch high "shield mount" are employed. The addition of the tube shields proper accomplishes nothing more than a hotter-running and shorter-lived set of tubes.

- - - - -

The 47K/150K resistors across the primary of the output transformer T<sub>6</sub> form an "inverse feedback" circuit in the 6CX8 output power-amplifier stage of the receiver. This is of help towards the elimination of distortion in this stage, as well as being of help toward the elimination of possible "instability" in the audio-stages of the receiver.

- - - - -

Some builders have inquired about using the Miller #1732 transformer as a substitute for the specified #1730. The #1730 has much more gain and selectivity than the #1732, which was designed for use in CB equipment primarily.

- - - - -

Many builders have complained that C-9 in their BFO not functioning correctly inasmuch as the oscillator's frequency (BFO pitch) remains unchanged regardless of the positioning of this capacitor. These builders have missed the point entirely; C-9 is not a frequency control unit. Instead, it is a means of providing a variable "injection voltage" to the injection grid of the 6BY6 product detector, with C-9's capacitance adjusted to that point which provides maximum audio output from the 6BY6. This C-9 adjustment is most easily accomplished by tuning in the steady, unmodulated "carrier" of the receiver's calibration oscillator and adjusting C-9 to that value of capacitance which brings about the optimum audio output. In wiring up the BFO oscillator, be certain that the "rotor" of C-9 is NOT grounded.

- - - - -

Although it was not mentioned in the article, you may notice the presence of two pin jacks in the photos; ( $J_3$  and  $J_4$  in schematic) one on the top of the BFO box and the other close to the grid of  $V_{3B}$  (2nd mxr.). Ted cleverly uses the BFO as a "signal generator" to align his 2nd i.f. strip. To make it convenient to do so at any time -- first, an insulated pin jack is installed in the right-hand, front corner (top) of the BFO unit. Connect to the output side of C-9. Second -- install another insulated pin jack on the main chassis, connected to the grid of  $V_{3B}$ . Make a "jumper" of flexible wire, to connect the two pin jacks. This will feed the BFO output directly into the 2nd mixer tube grid. To use: pull out the 1710 kc. xtal and go ahead with your i.f. alignment after setting your BFO pitch control at a center position. When finished, remove the jumper and reinsert the xtal. It is assumed that you followed the original alignment procedure first, then will use this BFO signal procedure to align the i.f. strip to near-perfection.

- - - - -

Loused up,  $L_1$ ,  $L_2$  and  $L_3$  coils can completely ruin an otherwise VFB HBR-13C receiver. When correctly approached, the fabrication of a properly functioning set of front-end coils is a relatively simple matter. There is no excuse for the "comedy of errors" sometimes present when the constructor insists on "trying something different" or goes on his own without first learning just what it is he is trying to do. The five-page "coil-winding" data is available from Ted or from me -- 50¢, postpaid.

- - - - -

The "heart" of any communications-receiver is its front-end. Insofar as the HBR receivers are concerned, the HI-Q low-loss plug-in coils are just as vital to the optimum performance of the front-end as the highly efficient circuit and physical layout in which they are used. In other words, louse up the L-1 L-2 and L-3 coils and automatically that particular HBR receiver is seriously handicapped from the start.

Long ago it was proved to me that the average HBR receiver constructor finds the fabrication of the front-end coils the most difficult and baffling part of the entire project. Left to his own devices, almost invariably he seems to go out of his way to make the task as difficult and non-efficient as possible. The result is a set of coils which leaves much to be desired, both physically and electrically. Yet, when approached in the correct manner there is nothing difficult about the whole thing. With these thoughts in mind, the following step-by-step instructions are written.

Step #1. Solder and chrome-plate have no affinity, one for the other. Therefore, get rid of the chrome at the tip-ends of the coil-form pins. Pins #1, 3, and 5 will encircle a single #26 bare wire when the coil is completed, therefore the original pin-holes are large enough. Nevertheless, use the smallest blade of a run-of-the-mill pocket-knife to ream out these holes sufficiently, the chrome is removed, exposing the brass underneath. Pins #2 and 4 will encompass two #22 bare wires. Ream these two pins sufficiently the two wires will slip through with no difficulty.

Step #2. Drill the coil-form holes for the insertion of the wires with a drill large enough that the wire can be inserted easily; a  $3/32$ " or  $1/8$ " size for example. The hole for the "tapped-lead" to pin #3 should be  $1/4$ " in diameter, to provide some leeway for the subsequent "up or down" movement of the tapped-turn during the final turns-spacing adjustment of the secondaries. Handle this  $1/4$ " drill with care. It is possible to crack or split the phenolic-form if "bull in a china shop" tactics are used at this point. In every instance the coil-form holes are placed in a straight vertical line directly above its companion pin. Always, pin #1 is used as the starting-point for the primary winding. Drill this hole as close to the extreme bottom inner-end of the form as possible, with drill-point barely clearing the inner-base of the form. Always, pin #5 will be the terminating point for the opposite (upper) end of the primary inductance. Make it a practice to position the "center" of this hole  $9/16$ " above the lower outer end of the form, which in turn will provide room for the upward or downward positioning of the primary-coil during the final adjustment of the "pri-sec" coupling. (Use the blade-end of a small screwdriver to shove the primary up or down during this adjustment.) Always, the primaries are wound with #26 enameled wire, in a closewound (non-spaced) manner. Always, pin #2 will be the starting-point (lower end) of the secondary-inductance. Make it a practice to center this hole  $3/4$ " above the lower outer end of the form. All secondaries other than the 75/80 meter band are wound with #22 enameled wire. (#26 enameled is used for the latter.) Always, pin #4 will be the terminating point for the opposite (upper) end of the secondary-inductance. The coil-data chart gives the "normal" vertical-space required for the overall secondary. Add  $1/8$ " to this figure and center the #4 hole accordingly. The  $1/8$ " provides sufficient leeway for any required variation in the normal "turns-spacings" during the final adjustment of this coil.

Bottom  
L1-C1  
L2-C2  
L3-C3  
C9  
C10

2  
3  
4  
5

Always, pin #3 will be the terminating-point for the lead to the "tapped" turn of the secondary. Center this hole  $1/16$ " below the vertical-height used for the pin #4 hole. True of L-3 only. Usually L-1 and L-2 tapped at some midway point. Mentally calculate location  $1/4$ " hole. When all the holes have been drilled, use the small blade of a pocket-knife to remove the "burrs", on both inner and outer surfaces of the coil-form.

Step #3. Always, the "primary" is wound first. Scrape bare the free-end of the spooled #26 enameled wire about  $3/8$ ". Slip this end of the wire through the hole above pin #1 and down through the pin until the wire-end extends about  $1/4$ " beyond the tip-end of the pin. Solder into position using only enough solder to do the job satisfactorily. (You might want to remove the wire at some future date. A completely filled pin is difficult to clean out.) Break off the excess wire flush with the end of the pin. (Place a pair of dykes in your right-hand trousers-pocket. You'll soon be in need of them.) Unspool a sufficient length of the #26 wire to form the complete primary, plus an additional 3 or 4 feet, being careful to avoid "kinks". (Approximately  $4\ 1/4$ " length of wire required for each turn.) Securely tie the spool-end of the wire to a convenient door-knob. Pick up the coil-form, holding the pin-end to the right and with pin #1 atop the form, and back off until the slack is removed from the wire. While holding the form at its two ends with both hands, slowly and carefully apply pulling-pressure on the wire, literally "stretching" it  $1/4$ " or thereabouts, thereby completely straightening-out the wire. Still using both hands, and with pin-end of the form to the right and pin #1 atop the form, hold the form at about a "belly-button" height and while applying just enough pulling-pressure to keep the wire taut, slowly rotate the form in an "anti-clockwise" direction. (The anti-clockwise rotation will keep the turns in sight as the coil is built up to the required number of turns.) Close-wind the entire primary other than the final half-turn, which is "angled-off" slightly in order the terminal-end will engage the coil-form hole above the #5 pin. Place the first one or two fingers of the left-hand inside the form and the thumb of the left hand atop the final turn. Apply sufficient "thumb and finger" pressure, the final turn will be securely held in position for the ensuing few minutes. With right-hand, remove the dykes from trousers-pocket. Cut the wire approximately 4" beyond that point where it crosses over the #5 pin hole. Mentally calculate the point on this 4" length of wire which eventually will be encircled by the tip-end of pin #5. Scrape bare this portion of the wire. Thread the wire through the coil-form hole and down through pin #5, avoiding any kinks in the wire. Pull the wire taut (BUT GOOD) and bend it sharply over tip-end of the pin. Cut off the wire about 1" beyond the pin. The sharp bend will hold the wire in position temporarily. Only NOW can the thumb-and-finger pressure of the left-hand be released. Stand the form on its top-end and with the wire still in its bent-over position, solder securely to the tip-end of the pin #5. Break off the excess wire flush with the end of the pin. Use the small blade of the pocket knife to scrape off all exterior solder from pins #1 and 5. Provided these instructions were followed to the letter, the primary will have been tightly and snugly wound, and will stay that way during the further fabrication of the coil.

Step #4. The secondary is wound using the same "door-knob" and "thumb and finger" methods employed for the primary, EXCEPT!!!! Temporarily, the starting and finishing ends of the wire are NOT soldered to the pins.

Scrape bare about  $3/4$ " at the tip-end of the spooled #22 wire. Feed the wire through the coil-form hole and down through pin #2, about  $3/8$ " past the tip-end of the pin. SHARPLY BEND the wire over the end of the pin and bring it around to a position tightly PARALLEL with the pin. The wire now will be anchored during the ensuing winding of the secondary. It is not imperative that the turns-spacings be too exact at the time the turns are being wound into position. Instead, an easy matter to slide the various turns into their correct location after the fabrication of the coil has been completed. The final turn of the secondary is cut approximately 4" beyond the point where it crosses over the coil-form pin #4 hole, and then scraped bare at the required spot. Thread the wire through the hole and down through pin #4 pull taut, and SHARPLY BEND over at the end of the pin into a position parallel with the pin. Cut off the excess wire  $3/8$ " above the tip-end of the pin.

Step #5. Re-arrange the secondary turns-spacings to conform with the "vertical length" called for in the coil-data chart, with the final (upper) turn passing over the approximate center of the  $1/4$ " "tapped turn" hole. Scrape clean that portion of the final turn which passes over the hole; top and both sides of the wire. If available, apply a thin coating of non-corrosive flux. Thoroughly CLEAN and TIN the small tip of a REALLY HOT iron and carefully apply it to the bared spot of the wire, maintaining contact only long enough to thoroughly TIN the wire. Excessive periods of time or pressures will melt the coil-form and embed the wire in the plastic.

Step #6. Cut off a 4" length of #26 enameled wire and scrape completely bare. At one end form a small "fish-hook" shaped half-circle. Thoroughly TIN this end of the wire. Insert the straight end through the coil-form hole (at the upper side of the tapped turn) and thread it through pin #3. Pull taut enough only to bring the "fish-hook" into an encircling contact with the tapped turn of the secondary. Again, apply the CLEAN, TINNED, HOT iron, just long enough to "sweat" the joint together. Arrange the "dress" of this lead so that it lays against the inner wall of the coil-form, and with about  $1/8$ " of slack between the tapped-turn and pin #3. Solder the wire at the tip-end of the pin. Break off the wire flush with the tip end of the pin, and scrape free of all external solder. In passing, the  $1/8$ " slack will allow for a corresponding up or down movement of the tapped-turn during the subsequent final-adjustment of the secondary "turns-spacing", should it be required.

Step #7. Cut off two 4" lengths of #22 wire and scrape both completely bare. Solder one of these wires to the "soldering-lug" end of the spider which makes contact with the rotor of the specified "APC bandset capacitor". Solder the second wire to that "APC stator-stud end" which is located at the opposite side of the capacitor. Extend both wires in a straightaway downward direction from the capacitor. If the capacitor is to be located in an L-3 coil, solder the silver-mica fixed-padder between the two wires, directly underneath the APC capacitor. All L-3 N-750 temperature-compensating fixed-capacitors are mounted externally, as described on page 17, March 1963 QST. When referring to the explanatory sketches on this same page, keep in mind that in this instance the two "primary coil pins" are incorrectly labelled, in a reverse manner. The pin labelled #1 should be labelled pin #5; the pin labelled #5 should be labelled #1. Otherwise, both drawings are correct. Note that the primary and secondary are wound in the same direction, always. A corrected set of these drawings appeared in the follow-up article, April 1964 QST.

Step # 8. Insert the two APC connecting leads into the proper pins of the coil-form; the "rotor" lead to pin #2, the "stator" lead to pin #4. ( A reversal will bring about extremely bothersome "hand capacity effects" when the subsequent tuning of the APC capacitor is attempted.) Pull both leads taut, to the point the APC is properly seated in the upper groove of the form. Place lengthwise between APC base-plate and coil-form a 1" length of the THIN end of a flat-sided wooden toothpick, and jam it tightly into place with the blade-end of a small screw-driver. Be careful to insert the toothpick at that end of the base-plate which does not in turn shove the rotor-plates so close to the inner-wall of the coil-form that the rotor-plates cannot be turned. The wedged toothpick will insure that the APC capacitor will be held securely in position during the subsequent experimental adjustment of the secondary turns-spacings and pri-sec "coupling", prior to the application of the DUCO cement. With the two pin-end leads to the secondary still in a "bent-over" position, solder into place the two leads which now emerge from both pins #2 and 4. Straighten out the two bent-over leads and break off all four leads, flush with the tip-ends of the two pins. Remove all exterior solder from both pins. Provided these instructions were faithfully followed, the coil (or coils) will not only be good looking, but good performing as well. And accomplished in rather an easy fashion no doubt?

Step #9. There now remains the final adjustments for correct band-coverage, tracking, and pri-sec coupling, as discussed and explained in the various pertinent QST articles; March and April 1963; April and July 1964. Immediately any set of coils is adjudged satisfactory on all the above counts, the turns should be cemented into permanent position with a minimum amount of DUCO cement, plus a generous application between APC base-plate and coil-form. It is my personal opinion that this can be done within a 24 hour (or less) period of time following the completion of the coils, rather than anything up to 90 days later. Just so long as the cementing is not done, just that long will the performance of the coils tend to be sub-standard, due to vibration and slippage of the various inductive elements.

---

See my comments on page 38 April 1964 QST in regard to possible "over-coupling" between the L-1 pri-sec coils when the receiver is connected to a reasonably efficient antenna-system. It is possible to remove one or more turns from the primary of any coil without disturbing any other portion of the assembly. Hold the form in an UPRIGHT position and apply a CLEAN, WELL-TINNED, HOT iron to the tip-end of pin #5, which is connected to the UPPER end of the primary. Allow 5 or 10 seconds for the solder to melt, then violently "flip" the form in that direction which will tend to throw the melted solder out of the pin. The "trick" to this operation is to do the "flip" almost simultaneously with the removal of the iron, in order that the solder will have not the slightest opportunity to reharden. Probably necessary to repeat the operation a second or third time before the solder is completely removed. Be careful not to apply too much pressure between iron and pin, inasmuch as the coil-form will be softened at the base of the pin and too much pressure will cause a dislocation. Slip a small pen-knife blade underneath the upper turn of the primary, where it enters the pin #5 hole and endeavor to pull the wire from the pin. Often times there will remain a small amount of solder which persists in maintaining the soldered-joint.

In that case lay the soldering-iron on the bench and while holding the tip-end of pin #5 against the iron with one hand, use the other hand to manipulate the knife-blade in the proper direction. Almost immediately the small remaining amount of solder will melt and the wire will slip free. Cut off one or more turns of the wire as desired, keeping in mind that the wire must not be cut off so short that it then will not reach pin #5. Prior to attempting to re-thread the wire through the pin, use the small blade of a pen-knife to ream out the #5 coil-form hole in an upward (vertical) direction to an overall length of approximately 1/4". Otherwise the "angle of re-entry" will be too sharp for the re-insertion of the wire. Bend the free-end of the wire into a slightly semi-circular shape prior to starting the re-threading maneuver. (All of which may sound somewhat complicated, but actually "nothing to it". I do it regularly; mostly for others who were not so fortunate as to own a copy of these instructions. HI.)

73

Ted W6TC Jany. 15th. 1965

EXAMPLE:

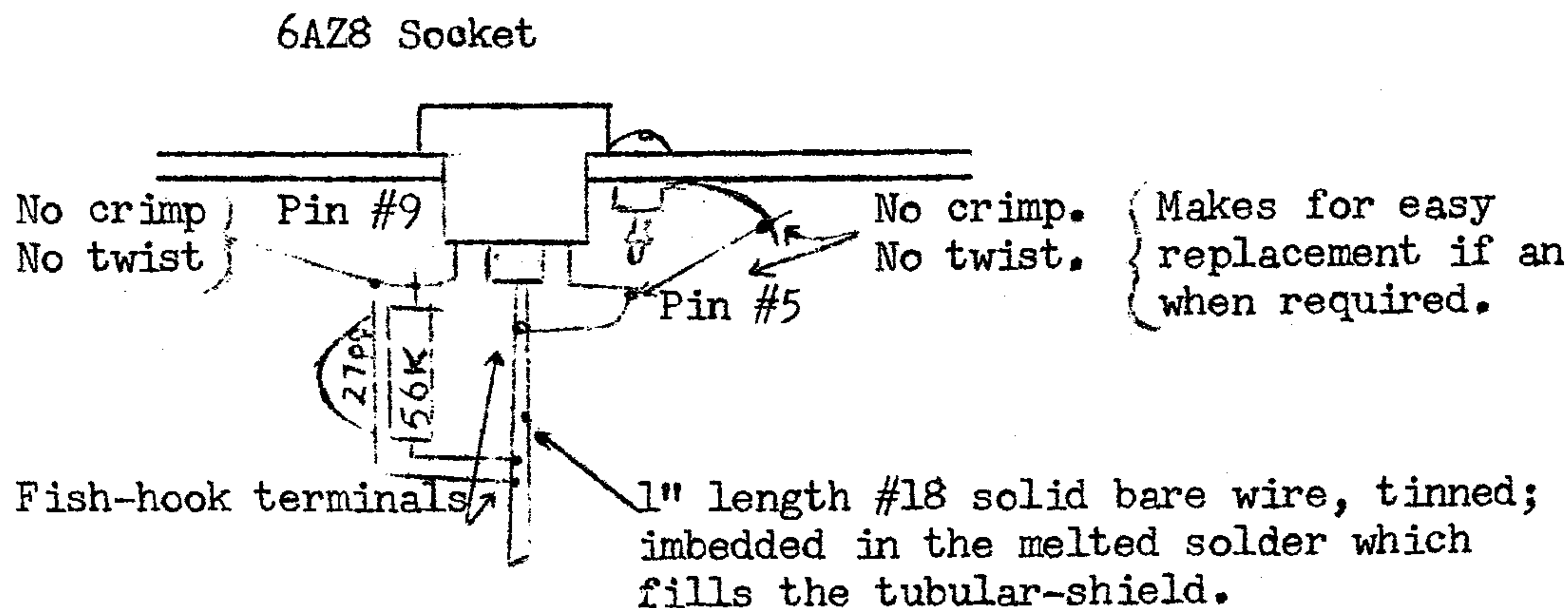

My latest idea for taking full advantage of the "vertical space" underneath the chassis. Provides a cleaner look, and much more room for the R/C components as compared to the usual helter-skelter approach. Use throughout the recvr.

*The pretinned socket-pins are remelted for installations of the small-parts leads.*

HBR-13C\*

(Eddystone #898 Dial)

PARTS LIST

C<sub>1</sub>, C<sub>2</sub>, C<sub>3</sub>, C<sub>4</sub>, C<sub>10</sub> - See coil tables, March 1963 and April 1964 QST.

✓ C<sub>5</sub> - 3-section variable, 5.5 - 23 - pf. per section (Miller #2102 or JWM 1461-BS).

⊗ C<sub>6</sub> - Internal tube capacitance; external capacitance not required.

⊗ C<sub>7</sub> - 2-pf. dipped silver mica.

⊗ C<sub>8</sub> - 1-pf. dipped silver mica.

✓ C<sub>9</sub> - 10-pf. variable, screw driver adjustment (Hammarlund MAPC-15),  
cut down to two rotor and two stator plates).

✓ C<sub>11</sub> - 15-pf. variable (Hammarlund MAPC-15B).

✓ C<sub>12</sub> - 50-pf. variable (Hammarlund MAPC-50B).

✓ C<sub>13</sub> - Dual electrolytic, 60 uf. per section, 450 volts (Sprague TUL-2772 or equivalent).

✓ CR<sub>1</sub>, CR<sub>4</sub>, inc. - Silicon diodes rated at 600 volts p.i.v., (International Rectifier type 1N1096, or equivalent).

✓ CR<sub>5</sub> - High back-resistance diode (1N54 or equivalent).

F<sub>1</sub> - Type 3AG fuse, 3 amps., 250 volts.

F<sub>2</sub> - Type 3AG fuse, 1/2 amps., 250 volts.

✓ J<sub>1</sub>, J<sub>2</sub> - Open-circuit jack.

✓ J<sub>3</sub>, J<sub>4</sub> - Pin jack (insulated type).

L<sub>1</sub>, L<sub>2</sub>, L<sub>3</sub> - See coil tables, March 1963 and corrected coil pin connection sketch of April 1964 QST.

✓ L<sub>4</sub>, L<sub>5</sub> - 4 henrys, 90 ma. (Triad C-9X),

✓ M<sub>1</sub> - 0-1 d.c. milliammeter, D'Arsonval movement (Lafayette 99-2513 or equivalent).

✓ P<sub>1</sub> - Fused line-plug for type 3AG fuses.

✓ R - 2000-ohm wire-wound control, not over 1-1/4 inches in diameter, 5 watts



- ✓ R<sub>1</sub> - 10,000-ohm wire-wound control, (same type as R ).
- ✓ R<sub>2</sub> - 5,000-ohm wire-wound control, (same type as R ).
- ✓ R<sub>3</sub> - 0.5 megohm, audio taper.
- ✓ R<sub>4</sub> - 200-ohm WW control, (same type as R ).
- ✓ R<sub>5</sub> - 3000-ohm WW control, (same type as R ).
- ✓ S<sub>1</sub>, S<sub>4</sub> - D.p.s.t. toggle, (must be small 3 amp. type).
- ✓ S<sub>2</sub>, S<sub>3</sub>, S<sub>6</sub> - S.p.s.t. toggle, (must be small 3 amp. type).
- ✓ S<sub>5</sub>, S<sub>7</sub> - D.p.d.t. toggle, (must be small 3 amp. type).
- ✓ S<sub>8</sub> - S.p.d.t. toggle, (must be small 3 amp. type).
- ✓ T<sub>1A</sub>, T<sub>1B</sub> - 1800-kc. J-tran., i.f. transformer, slug-tuned (Miller 1730).

*S<sub>2</sub> - SPST rotary*

Padded down with 62 pf. silver mica capacitors across both primaries and secondaries and tuned to 1610 kc.

- ✓ T<sub>2A</sub>, T<sub>2B</sub>, T<sub>3</sub>, T<sub>4</sub> - 100 kc. J-tran., i.f. transformers, slug tuned (Miller 1709).
- ✓ T<sub>5</sub> - 100-kc b.f.o. coil, slug-tuned (Miller 1711).
- ✓ T<sub>6</sub> - Audio output; 7000/4 ohms, 40 ma. primary (Triad S-7X or Stancor A3878).
- ✓ T<sub>7</sub> - Power transformer; 520/550 v., c.t., 90/110 ma. 6.3 volts, 4/5 amp., (Triad R-12A), or (Stancor PC-8420)

- ✓ Y<sub>1</sub> - 3500 kc. crystal.
- ✓ Y<sub>2</sub> - 1710 kc. crystal.

*Hammond 270 FX*

*275-275 V @ 150 ma  
# 8.47*

Mechanical items:

Cabinet: 15 x 11 x 9 inches, steel, complete with panel, (Wyco CR-7725, gray hammertone).

Dial: -- Eddystone #898, 9 - 3/16 x 5 - 3/4 inches.

B.F.O. Enclosure: -- 3 - 1/4 x 2 - 1/8 x 1 - 5/8 inch aluminum, channel-lock (LMB 000) *1411D*

Main chassis: 10 x 14 x 3 inches, aluminum with braced corners. (Premium, manufacturer). Available from Lafayette Radio.

Front-end sub-chassis: 5 x 7 x 2 inches, aluminum.

(Premium, manufacturer). Available from Lafayette Radio.

✓ Flexible coupling to connect dial shaft to 3-gang shaft,  
(James Millen 39006).

- \* In addition to the mechanical changes made necessary by the large Eddystone #898 dial, the circuit of this receiver contains numerous modification of the original HBR 11/12 circuits. The parts list of the two receivers are not 100% interchangeable.

October 1, 1965

- T7 (Alternate) Stancor #PC-8420 - (slightly smaller and less expensive than Triad R-12A) - rated 520 v. center-tapped at 90 M.S., 6.3 v. at 4 amps., no 5 v. winding so for use with silicon-diodes only.
- RFC #1 22 turns of #22 enamel wire, closewound to give an inside diameter of 1/8". Self-supporting and mounted horizontally at the L-2 coil socket. (Primarily not an RF choke. Instead serves to lower the frequency of the possible resonant UHF circuit in the "plate" of the tube, <sup>which some-</sup> times could cause parasitic oscillations.)
- RFC #2 This UHF RF choke to be installed directly to tube-socket pin with .02 bypass capacitor connected on B end. Consists of 12 turns of #22 enamel wire, closewound to give inside diameter of 1/8". Self-supporting and mounted in a vertical position.

Dear *Wm*:

Thanks for your inquiry. Please excuse this mimeographed reply.

As indicated in the Oct. 1965 QST article, there are several approaches to an HBR-13 receiver.

(1)--Some HBR-8/11/12 owners may now wish to further modify their receiver per the Oct. 1965 QST article, retaining the original relatively small cabinet and chassis.

(2)--Some might like to build the HBR-13 from scratch. Here, two choices are available:--Use the smaller HBR-8/11/12 cabinet and chassis, #598 Eddystone dial plus Jackson vernier arrangement shown on page 18 of Oct. 1965 QST (highly recommended), and employ the slightly modified chassis layout described in the above article.

(3)--Use the larger cabinet and chassis (plus front-end sub-chassis) required when the larger #898 Eddystone 110/1 ratio dial is to be employed, as was done with the HBR-13C pictured in Oct. 1965 QST.

(4)--Some builders might prefer to modify the last mentioned layout slightly by mounting the #898 Eddystone dial toward the left-center of the panel, as was done in the HBR-16 described in June 1961 QST. There is no law against this arrangement obviously. Instead, I personally just happen to like things arranged "on center", as pictured in Oct. 1965 QST. I still have a few drawn-to-scale panel/chassis templates of this HBR-16 layout, price 25¢ (while they last).

The following helpful items are available to all HBR builders.

From Ted Crosby, W6TC, 28901 Crosby Drive, Sun City, Calif. 92381.

(1)--Commercial-quality 8X10 inch glossy originals of the three HBR-11 photographs which appeared in the April 1963 issue of QST, complete with penned-in marginal explanatory notes by Ted. Price \$2.00 postpaid.

(2)--Ted's five-page set of easily followed step-by-step instructions covering the correct approach to the mechanical fabrication of the plug-in coils used in the front-ends of all HBR receivers. Price 50¢ postpaid.

From Alex Stewart, WA4ZNI, 916 Croton Drive, Alexandria, Va. 22308.

(1)--Commercial-quality 8X10 inch glossy originals of the three HBR-13C photographs which appeared in the Oct. 1965 QST. Price per set \$2.00 postpaid.

(2)--Drawn-to-scale panel and chassis drilling templates for the Oct. 1965 QST HBR-13C receiver, a corrected 16X22 inch blow-up of the QST HBR-13C schematic, a complete HBR-13C parts list, and several pages of helpful mechanical and electrical constructional notes pertaining to the HBR-13C receiver. Price of this complete "HBR-13C package" \$2.00 postpaid.

(3)--Drawn-to-scale panel and chassis drilling templates for the HBR-8/11, plus corrected "blow-ups" of both HBR-8 and HBR-12 schematics. Price \$1.50 postpaid.

(4)--The 16X22" HBR-13C schematic only, for those who desire to build an HBR-13 on the smaller HBR-11/12 chassis. Price \$1.00 postpaid.

(5)--The drawn-to-scale HBR-8/11 drilling templates only, for those who desire to build an HBR-13 on the smaller chassis. Price \$1.00 postpaid.

(6)--Ted's five-page set of coil making instructions, as mentioned above. Price 50¢ postpaid.

It is to be understood that all of these postpaid quotations are based upon a normal first-class postage rate. Air-mail is something else again, and purchasers should be guided accordingly.

All HBR receiver parts are "standard", and therefore theoretically obtainable through any retail radio parts dealer. Even so, some of the parts do fall in the "hard to find" category. The Wyco cabinets and Triad transformers and chokes for example. Your local dealer may or may not be able to order these items for you. Exact duplicates of the Wyco cabinets are made by the Bud Mfg. Co., but in "black wrinkle finish" only. These Bud cabinets are listed in the current Allied Radio, Chicago catalog, (Bud types C-995 and C-975). Allied's "Knight" filter-choke #63U992 rated at 5.0 hys. at 65 ma. is an exact replacement for the Triad C-6X choke.

Allied also lists the 24-5P coil-forms, Millen #39006 slide-action flexible coupling, and Millen #33005 steatite 5 prong coil-sockets. Allied's "Knight" filter-choke #62U344 rated at 2.5 hys. at 130 ma. is a suitable substitute for the Triad C-9X or Stancor C-2303 filter-chokes used in the Oct. '65 HBR-13C. The Stancor PC-8420 power-transformer is a completely satisfactory substitute for the Triad R-10A and R-12A transformers, (slightly less plate-voltage than the R-12A) provided only that silicon diode rectifiers are used rather than the 5V4 tube.

For the past several years, Lafayette Radio, Syosset, L.I., N.Y. have carried many of the hard-to-find components used in an HBR receiver, including most of the J.W. Miller coils and transformers, Premier CORNER-BRACED aluminum chassis, Stancor power-transformers, and filter-chokes, and the various APC, MAPC and MAPC-B Hammarlund variable condensers. Recently, as a further service to their customers, Lafayette has added to their J.W. Miller line the following items:--#1461-BS tuning-capacitor (Lafayette #34-8605) price \$4.05; #2102 tuning-capacitor (Lafayette #34-8606) price \$9.75; #1709 100 kc IF transformer (Lafayette #34-8604) price \$2.25. The remainder of the J.W. Miller coils and transformers used in an HBR receiver are listed on page 355 of their 1966 catalog. To help you identify these items, the #1731 1610 kc link-coupled coil is Lafayette #34-8791; the #1730 1800 kc IF transformer is Lafayette #34-8789; the #1710 100 kc IF transformer is Lafayette #34-8784; the #1711 100 kc BFO coil is Lafayette #34-8788. The illuminated (basic lma. movement) D'Arsonval type S-meter used in all HBR receivers is Lafayette #99-2513. (A suitable substitute would be the larger Lafayette #99-2514). Additional HBR components obtainable from Lafayette would be the natural finish aluminum mini-boxes (Premier) on page 427 1966 catalog, (substitute AMC-100 for the LMB-00Z); the IRC 4 watt wire-wound pots., (type WPK) listed on page 334 of this same catalog; Stancor PC-8420 power transformer, Stancor C2303 filter-chokes, and Stancor A-3878 output-transformer. Finally, as a thoroughly satisfactory substitute for the GREY FINISH Wyco cabinets, see page 427 of the 1966 Lafayette catalog, and the "Premier" Streamlined Cabinets in particular. Due to the heavier, rounded-corner construction of these cabinets, they are two-inches longer overall than the comparable Wyco cabinet. Even so, the 9X15" panel of the HTC-203 is an exact duplicate of the Wyco #7725 used in the Oct. 1965 HBR-13C, and the panel/chassis construction techniques would be identical in both instances. (Lafayette's dimensional figures are incorrect. Actually the HTC-203 is 9X17X11 inches overall.) For the smaller HBR-8/11/12/13 receiver, the Premier HTC-202 should be used. However, in this instance the panel is 8 inches high rather than 7 inches for the Wyco #7723. It then is suggested that the panel mounted components all be shifted upward one-half inch (place the drilling-template 1/2" above the lower edge of the panel) when the HTC-202 is substituted. This will move the 7X13" chassis upward a corresponding 1/2", which in turn will clear the usual one-half-inch flange which appears across the lower front of the cabinet, and as a consequence the spacers between panel and chassis will not be required in this instance. One-half inch high supports at the rear side of the chassis will be required.

The Eddystone dials are obtainable ONLY from British Radio-Electronics, Washington, D.C. See their ads in any issue of QST.

The Jackson vernier is obtainable from dealers regularly patronizing the display pages of QST.

Both crystals and tubes will vary in their performance characteristics despite claimed ratings and specifications. Buy tubes made by a reliable manufacturer, and then check them in an accurate tube-checker prior to installation. Crystals can and do vary in their operational efficiency, regardless of brand or price.

All good luck and good fun to you in this project. I do wish it was possible for me to share the thrill and sense of personal satisfaction which inevitably accompanies a successful completion.

Some additional "loose ends".

With one or two exceptions, the HBR-13C schematic is correct, as published in Oct. 1965 QST, or in the blown-up version supplied by Alex Stewart.

Due to an oversight, the 1st. audio cathode-resistor (V9a) is 1000 ohms. This value should be increased to 3300 ohms  $\frac{1}{2}$  watt, for a more realistic 5 to 5 $\frac{1}{2}$  volts of grid-bias at this point. All HBR-9/12 modifications should include the 0.1 bypass capacitor called for in the HBR-13C schematic.

The proper oscillation of a sluggish or mediocre 1710 kc crystal will be more reliably obtainable if a 2 pf S-M fixed-capacitor is connected between "plate" (pin 1) and "gnd" of the 2nd. osc., V3a. In fact, were I redrawing the schematic as of today, I would specify 47 pf between "grid" (pin 9) and "gnd", and 5 pf between "plate" (pin 1) and "gnd", for the reasons given.

Finally, for reasons I will attempt to explain subsequently, the 2700 ohm cathode-resistors in the two mixer-tubes (V2 and V3b) are subject to change, provided optimum "mixer conversion-gain" is to be achieved. Up to certain limits, the greater the "mixer injection" the better the "mixer conversion-gain". Writing for Tom, Dick and Harry as I have endeavored to do over the years, I've made it a point to stay away from any and all highly technical subjects; I long ago learned "less said the better". But, at long last I've finally decided that this "mixer-injection" matter is so vital to the optimum performance of any and all HBR receivers, an attempt at a simple method of approach should be made.

Obviously, there has been "much water over the dam" since the original HBR-8/11 schematics were published in March/April 1963 QST. Ditto the follow-up articles in the April/July 1964 issues. It follows that if these receivers are to be brought up to date, the changes called for in the Oct. 1965 HBR-13C schematic should be made. For the most part, this will call for nothing more than changing the values of the original HBR-11/12 R/C components (or the addition of the missing R/C components) to coincide with the Oct. 1965 diagram. It is to be understood that I strongly urge that an HBR-9/12 be constructed rather than an HBR-8/11, for the reasons given in the April 1964 QST article. Mount the 6BH6 electron-coupled 1st. oscillator tube atop the chassis alongside the 1st. mixer tube, as suggested in the April 1964 article. For obvious reasons, the HBR-13C 6BC5 1st. mixer tube is to be preferred over the 6U8 pentode-section 1st. mixer called for in the original HBR-8/11/12 schematics. The smaller 7 pin socket for the 6BC5 tube is easier fitted into the available space than is the larger 9 pin 6U8 socket. Either tube works equally well as the 1st. mxr., with identical R/C values.

Carefully re-read the "editors note" on page 42, April 1963 QST. Note that the "ceramic form" 1731's will be resonant at 1610 kc when the threaded slug-tuning screw extends about 3/8" beyond its metal housing. Unfortunately, also resonant at 1810 kc when the screw extends approximately 5/8". Either 1610 kc or 1810 kc does provide the required "100 kc difference frequency" at this point, and to the uninitiated the receiver will work satisfactorily well with either resonant adjustment. But, #1 -- With about 15 db lesser gain with 1810 kc than when the correct 1610 kc resonance is present. #2 -- Inasmuch as the 1st. oscillator now must supply an "1810 kc difference frequency" rather than the correct "1610 kc difference frequency", the specified L-3 1st. oscillator "secondaries" will be incorrectly proportioned, and "much pulling and hauling" (often unsuccessful) of the L-3 "turns spacings" will be required if anything approaching "proper frequency coverage" is to be achieved. Heaven only knows how many improperly operating HBR-8/9/11/12 receivers are in use today, due solely to this incorrect 1810 kc adjustment.

Many have wondered why it was that the values of the specified "mixer cathode resistors" have differed so widely, model to model. Nothing more than a matter of trying to make an "educated guess" at the probable values of the "injection" at the "grids" of the two mixers in the average duplicate receiver, and the most satisfactory compromise value of cathode-resistor (mixer grid bias) in the majority of cases. The RF output of the 6BH6 electron-coupled 1st. oscillator is pretty much a predictable matter, provided only that the 6BH6 be a good one. Therefore, my upcoming comments in regard to the 1st. mixer very likely will be equally true of every duplicate receiver. Unfortunately, the 1710 kc crystal activity and resultant RF output of the 2nd. oscillator is a completely unpredictable matter. Even so, I now feel there is a relatively simple approach and solution, and I've decided to attempt to pass it along.

A reliably accurate 20,000 ohms per volt VOM will be required for making the to be discussed mixer-injection-voltage measurements (mine is a Simpson). Or, a similarly accurate VTVM also can be used. In either case, the  $2\frac{1}{2}$  volt AC scale of the meter should be used. The mixer-injection-voltage to either mixer-tube is measured between the "control-grid" of the tube and chassis-ground.

When C-7 is 2 pf and the 1st. mixer cathode-resistor is 2700 ohms, as per the Oct. 1965 HBR-13C schematic, the 1st. mixer injection will be little more than an almost imperceptible "forward deflection" of the meter. Now, if the C-7 capacitance is increased to 3 pf, the reading still will be almost imperceptible, but the "conversion-gain" will have been increased slightly. Finally, if C-7 is increased to 4 pf, (two 2pf's in parallel) and simultaneously the 1st. mixer cathode-resistor is made 3900 ohms rather than 2700 ohms, there will be a further slight increase in 1st. mixer conversion-gain, with the injection-voltage reading now having gone up to approximately 0.05 volt. The quoted injection-voltage figures will be 100% true, only when any amateur-band other than 7 mc is being used for the measurements. In the latter single instance, and for reasons I have been unable to fathom, the 1st. mixer injection quite likely will be higher than the quoted figures; even as much as 1 volt in some instance, when a 4 pf C-7 value is used. (more than 4 pf not recommended). (The use of a 3 or 4 pf. C-7 in connection with the 6U8 "triode" type of 1st. osc., is not recommended either, due to the increased "1st. osc. pulling" which would result from such a procedure. In reverse contrast, the 6BH6 electron-coupled 1st. osc. is not subject to this type of undesirable malfunctioning.)

The 2nd. mixer injection is an unchanging matter, insofar as the various amateur-band frequencies are concerned. Instead, subject to variation in amplitude in any individual receiver only when the capacitance of C-8, or its methods of connection between 2nd. osc. and 2nd. mixer tubes is changed. Assuming that the 1710 kc crystal used in any particular HBR receiver is of "average activity", and with the 1 pf C-8 connected between 2nd. osc. "grid" and 2nd. mixer "grid", (this is the arrangement called for in the original HBR-13C, October 1965 QST), the specified 2700 ohms mixer cathode-resistor will be of the correct value for maximum mixer-conversion-gain under this particular set of conditions. Quite likely, if the injection-voltage of this combination now is measured, the figure will be approximately 0.3 to 0.4 volts. Frankly, this is not an optimum set of conditions. Instead, for optimum 2nd. mixer conversion-gain/signal to noise performance at this point, the mixer-injection should be in the order of 0.8 to 1 volt, with a correspondingly higher value of cathode-resistor to match.

Temporarily at least, discard the 1 pf C-8 entirely. Instead, solder a  $1\frac{1}{2}$  or 2" length of #18 solid plastic-covered hookup wire to the "plate" (pin 1) of the 2nd. oscillator. Then, by bringing this variable type of C-8 into parallel proximity with the "nd. mixer "grid wiring" (pin 2), the mixer-injection probably

can be adjusted to the required 0.8/1 volt figure. If however, the 1710 kc crystal is of less than "average activity", it then may be necessary that the 1 pf C-8 must be restored, but in this instance connected between "plate" (pin 1) of the 2nd. osc. and "control-grid" (pin 2) of the 2nd. mixer. If and when the required 0.8/1 volt mixer-injection has been achieved, change the 2nd. mixer cathode-resistor to 6800 ohms rather than the original 2700 ohms.

In the subsequent necessary re-alignment of L-4b in the HBR-11/12, or T-1b in the HBR-13C, these particular inductances should be peaked only when the 2nd. mixer gain-control is "fully advanced". In 9 out of 10 cases, the 6800 ohm cathode-resistor will be correct for the injection-voltage figures mentioned. If however, the S-meter reading tends to increase when the 2nd. mixer gain-control is backed-off slightly from its fully-advanced positioning, the 6800 ohms is of too low a value. Its value should be made increasingly larger via progressive 1000 ohm jumps, to that point the S-meter reading falls off progressively when the mixer gain-control is backed-off slightly from a "fully advanced" positioning. (The additional cathode-resistor values are most easily and conveniently insertable between the "variable slider" of the pot. proper and the lead to the 6800 ohm cathode-resistor.) L-4B and/or T-1B must be repeaked each time the value of the 2nd. mixer cathode-resistor is changed.

Quite likely, once the 0.9/1 volt 2nd. mixer injection/higher bias conditions have been established, the 2nd. mixer "gain-control" no longer will "kill" the overall-receiver at the desired "9 or 10AM" clockwise positioning of this control, due to the resistance of the companion "series fixed resistor" now being of too high a value. The remedy is a reduction in the resistance of the series-resistor to that value required to restore the normal operational characteristics of this control.

The number of turns specified for the 14, 7 and 3.5/4 mc L-1 primaries (antenna coils) again are a "compromise"; nothing more than an "educated guess" as to the most satisfactory figure for the average HBR receiver. With all other things as they should be, these particular L-1 coils will be overly large for any HBR receiver which has been correctly "souped up" at the two mixers. Always, my own personal HBR receivers have incorporated these "optimum conversion-gain mixers", even though heretofore I have been reluctant to attempt to pass along the required procedures to others. And, just as might be suspected, always it has been standard practice for me to use a lesser number of antenna-coil turns on these three amateur-bands than is specified in the March 1963, or October 1965 QST coilcate charts; as follows. 14 mc--1 7/8 turns; 7 mc -- ONLY 7/8ths. of ONE turn; 3.5/4 mc--2 7/8 turns. Admittedly, a ridiculously small value of "antenna coupling" results from the use of these extremely small antenna inductances. That you could not get by with it in any receiver other than an HBR, I can and will assure you; assuming of course that the companion antenna-system is a half-way decent affair.

Along this same line of thought; in a correctly "souped up" HBR receiver, the overall-receiver-gain will be so great, the use of the "partial AGC control bus" no longer is practical. It simply does not give adequate overall AGC control of the receiver under these "souped up" conditions. Instead, the RF and 1610 kc 1st. IF amplifier stages in the HBR-13C (RF stage only in the HBR-11/12) should be disconnected from the partial AGC bus and reconnected to the "main" AGC bus. In the latter instance, the AGC control action of the overall-receiver will be excellent; begins to take hold at about an S-7 S-meter reading, with little or no apparent ear-level change in the audio-output of the receiver between this S-7 and a completely off-scale reading of the S-meter.

"STRAYS"

(#1)

The following information should be helpful to the HBR-13 builder -- most of it resulting from early correspondence from current builders, questions asked most frequently and some points the new builder may need.

---

From Lafayette Radio Electronics you can obtain the "Premier" cabinet -- stock No 12 R 8359. (Mfr. type No. HTC-203). Measures 9 x 17 x 11 inches and costs \$10.78. This is best available alternate to the Wyco CR-7725 -- in fact preferred by many due to extra venting louvers on back and cutout for rear connections already made. Finished in grey wrinkle. Has no flange so panel-chassis spacers are not required. Note: parcel post is famous for damaged goods in transit. Make certain you request parcel post (government) insurance on shipments -- especially for the cabinets. Express is more costly but may prove the better method of shipping this item -- again be sure you have insurance and check contents upon delivery.

---

At the time the "HBR-13C dope-sheet" was made up, a retail source-of-supply for the HBR builder located in the western half of the country had not been arranged. No longer the case. The R. V. Weatherford Co., 1095 East 3rd St., Pomona, Calif. has in stock practically every one of the parts used in both the HBR-11/12 and the HBR-12/13C, with the exception of the Eddystone dials, Jackson vernier, and Lafayette S-meter obviously. A complete parts list is included with all material mailed west of Miss., or you can obtain direct from Weatherford.

---

California orders should include the 4% sales tax and also make payment sufficient to cover shipping costs as any overage will be promptly refunded by Weatherford. A complete price list is available on request from Weatherford.

---

The completely enclosed speaker unit used on front panel of the HBR-13C is Lafayette's 99 R 6122 ... net, \$2.74. (page 373 of 1965 catalog).

---

March/April 1963 and April/July 1964 issue of "QST" still available from ARRL at 65¢ per copy. Individual pages (photostats) of out-of-stock issues are available from ARRL at 25¢ per page. (Text and schematics clear but halftones do not reproduce very well).



"STRAYS"

(#2)

Recommend you make "corrections" and additions to your set of notes etc., as indicated below:

Corrections for the five-page "coil winding" instructions: 2nd page, 2nd line: "hold" should be "hole." 3rd page, 2nd line: 3/6 should be 3/8; 2nd paragraph, 2nd line: make it "length"; 4th paragraph, 2nd line: "on" should be "one." 4th page, 6th line: "bass-plate" should be "base-plate." Last page, in "6AZ8 socket wiring example" add the following, "The pre-tinned socket-pins are re-melted for installation of the small-parts leads."

Corrections and additions to the HBR-13C "notes." (and answers to a few questions in recent letters to Ted Crosby and me). "Why the 10 ohms in lead to S-meter lights?" Ans. - to prevent premature burn-out; these lights won't stand up at 6.3 v. Ans to another question about switching in and out the back-to-back IF transformers: Know of no PRACTICAL and EFFICIENT switching method for these transformers. They are detuned when such switching is attempted. Not to overlook the oscillatory-instability introduced by the insertion of the switch or switches. Page 2, 1st paragraph: -- "will show a weak audio-image, etc." Page 3, 4th paragraph: "If your Miller 1461-BS etc." (make whole paragraph "plural" rather than "singular." Page 3, last paragraph: eliminate second sentence. Page 4, paragraph 4: there is now no need to "nibble" off any but the two "SIDE" front flanges. Nor is there any longer the need for the "notch" in top front flange -- the template has lowered the Eddy dial enough to take care of this. Page 5, 1st paragraph: there are no "shielded grid leads in receiver. Wire used is called "shielded grid wire" and this may cause confusion to some. Page 5, paragraph 5: add, "Not as efficient (less volume) as the recommended external spkr. discussed in next paragraph." Page 7, paragraph 2: should read "Serves to lower the freq. etc." Same page, in the "NOTE," sentence should read, "...the .02 bypass capacitor directly to pin #2 etc."

If you'll compress slightly the bandspread of your 40 meter osc, coil, it will cover 7335 KC at the top of the dial. This will permit tuning in CHU, the Canadian Frequency Standard station. This signal comes in very strong down the east coast and about S-9 in most of the western U.S. Saves having to build special coils for WWV type checks.

The correct "clockwise" rotation of the various gain-controls will be present only when the "ground connection" to the resistive element of the potentiometer is correctly made. In the case of R-1, R-2, and R-3, the gain increases as the rotating arm of the pot. approaches the "grounded" end of the resistive element. In the case of R-4, the exact opposite is true; the gain increases as the arm approaches the "ungrounded" end of the element. So, if you end up with any of these pots. operating in an opposite to normal fashion, the correct rotation will be achieved by a reversal of the two leads at the outer terminals of the pot.

